

Modeling and Simulation of Heterogeneous Systems With SystemC-AMS: Application to Wireless Sensors Network

H. Aboushady, F. Pêcheux, M. Vasilevski and M.M. Louërat

Hassan.Aboushady@lip6.fr

**LIP6 Laboratory
University of Pierre & Marie Curie, Paris VI**

Outline

- **Introduction**
- **SystemC-AMS Models**
- **Model Refinement Based on Transistor-Level Characterization**
- **MEMS in SystemC-AMS**
- **Application: Wireless Seismic Sensor Network**
- **Conclusion**

Commercial Wireless Sensors Node

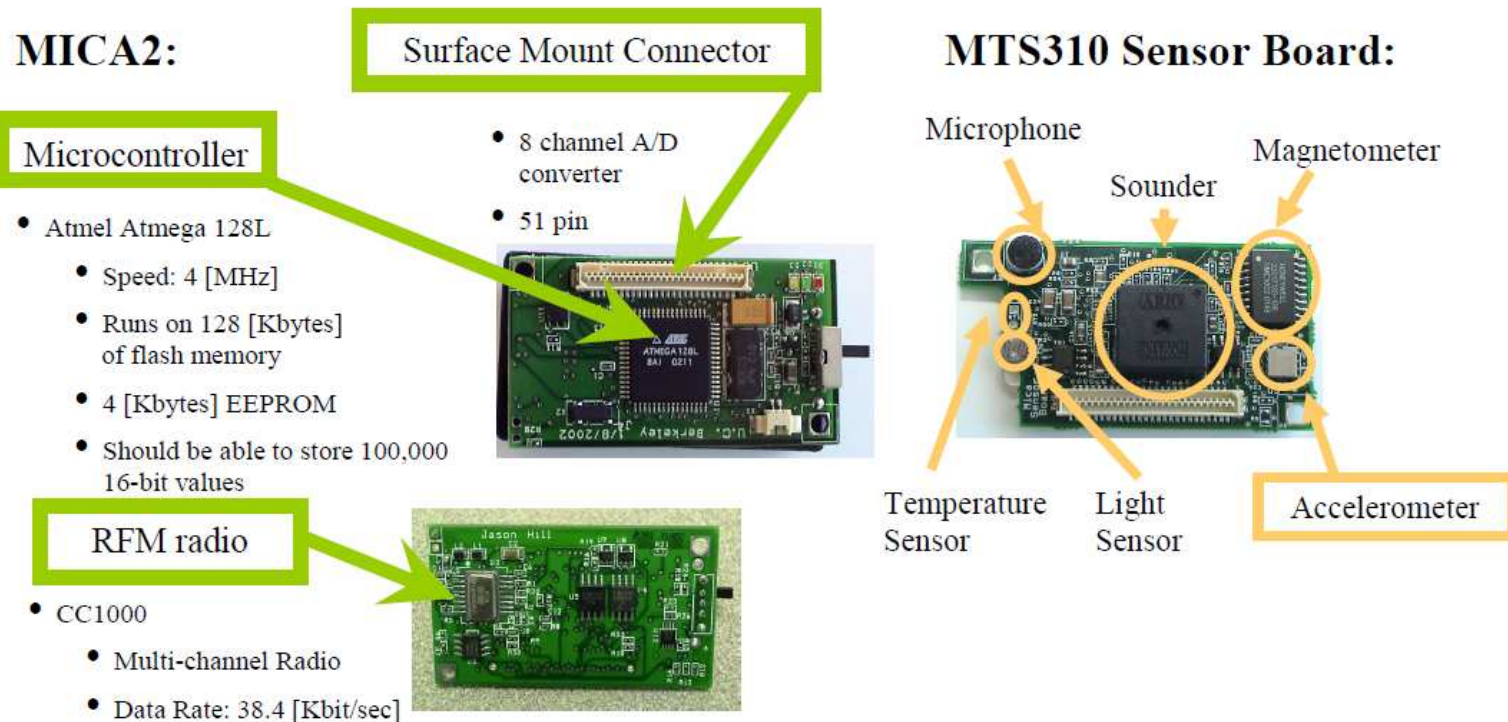

- **General Purpose**
- **Bulky, high power consumption**
- **Not adapted to many applications**

Heterogeneous System Design

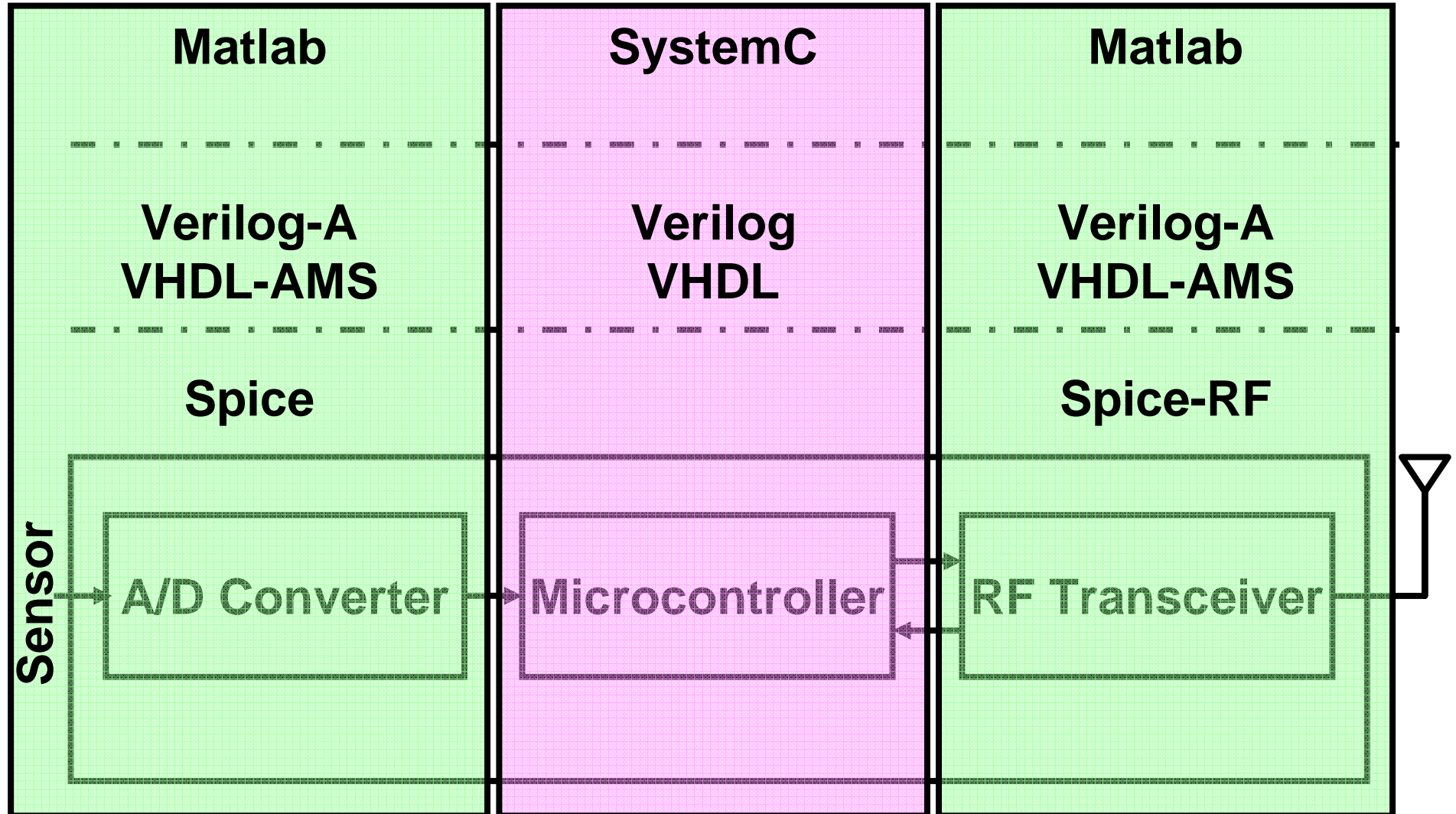

Positioning SystemC-AMS

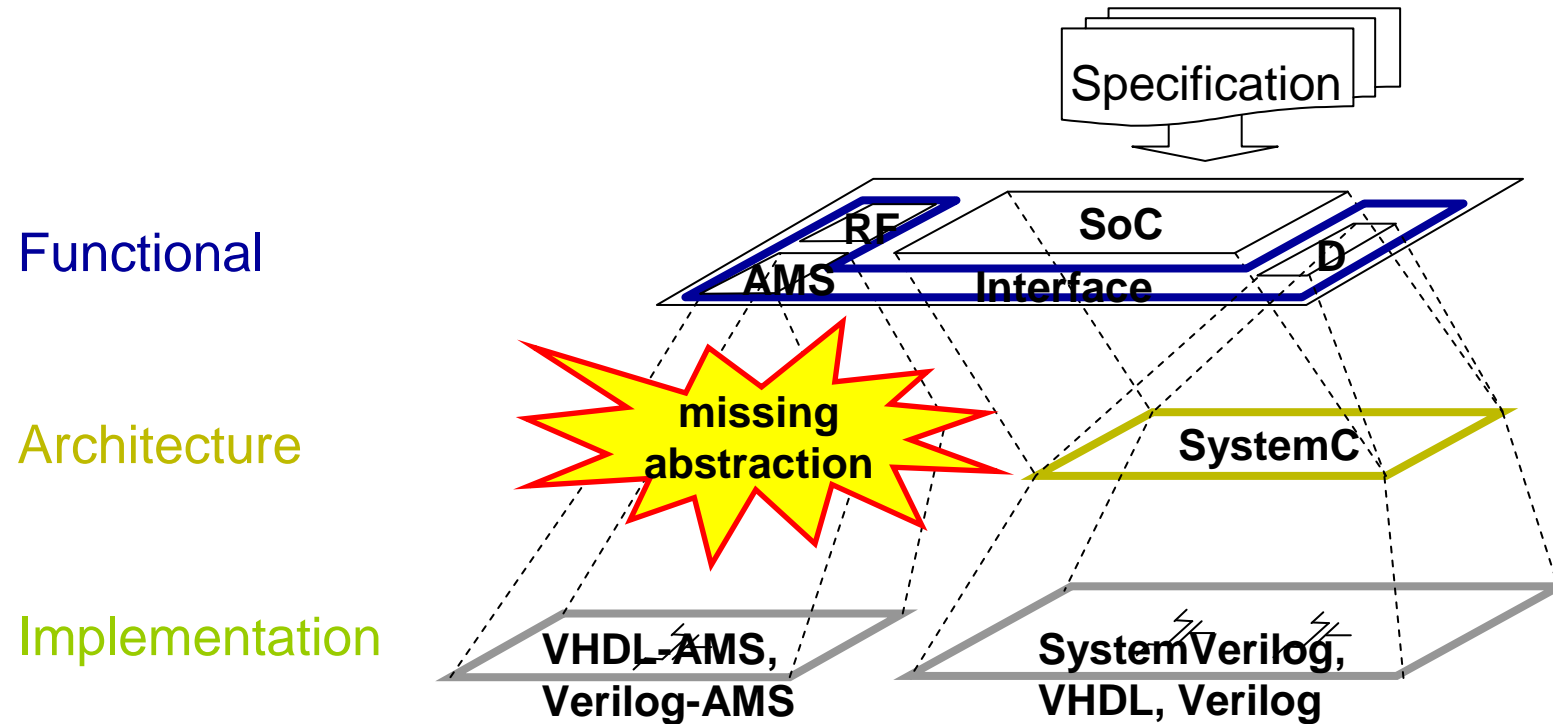

OSCI AMS Working Group



- Steady growth in AMS WG: 53 individuals from 19 organizations
 - strong drive from semiconductor industry
 - full support of universities and research institutes
 - growing interest and participation of EDA vendors

Outline

- **Introduction**
- **SystemC-AMS Models**
 - **Wireless Sensor Network Node**
- **Model Refinement Based on Transistor-Level Characterization**
- **MEMS in SystemC-AMS**
- **Application: Wireless Seismic Sensor Network**
- **Conclusion**

Models of Computation

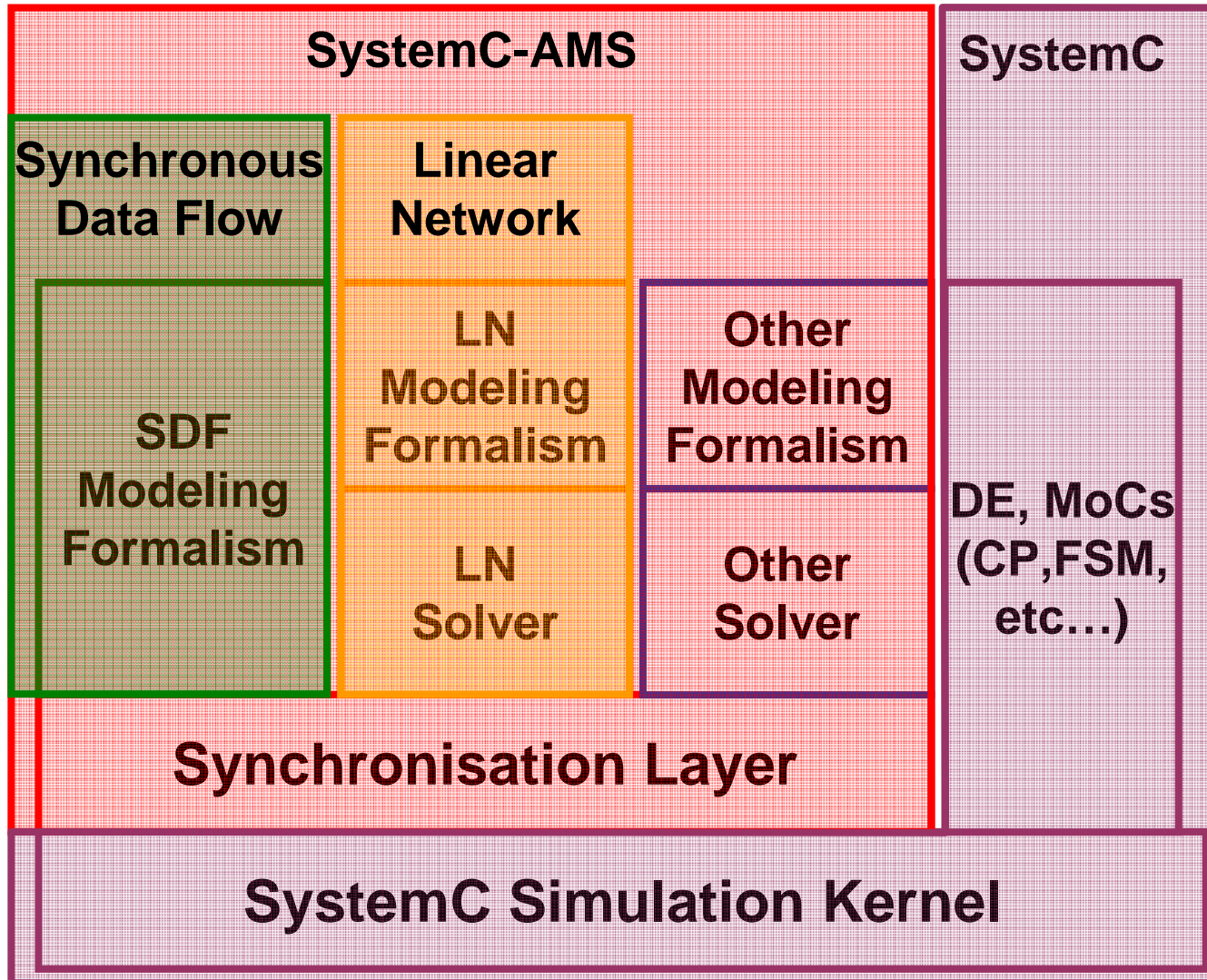

Models of computation :

- **Conservative Linear network**
- **Synchronous Data Flow**

2.b SDF Behavioral Description

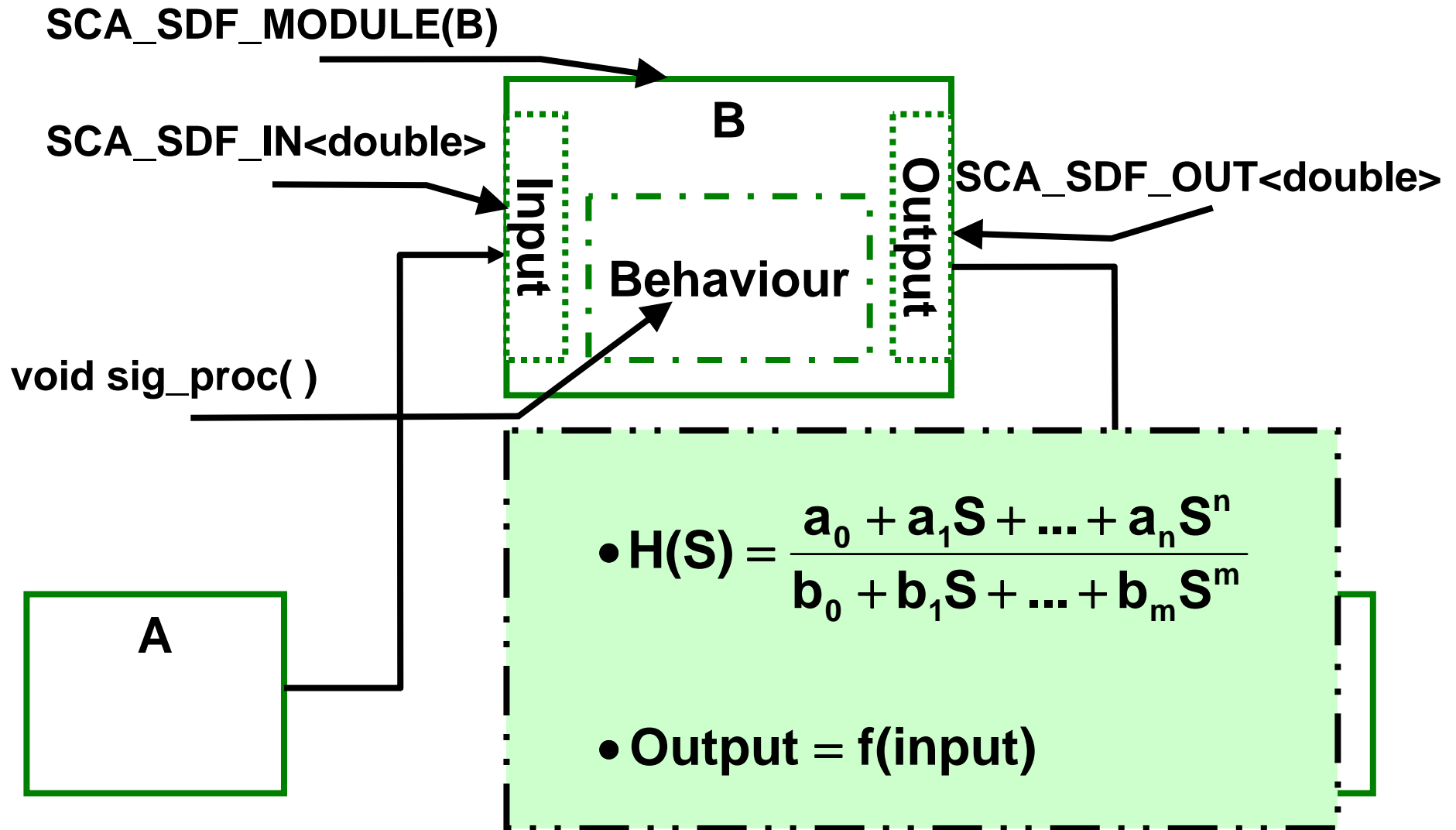

SDF Multi-Rates

Cluster

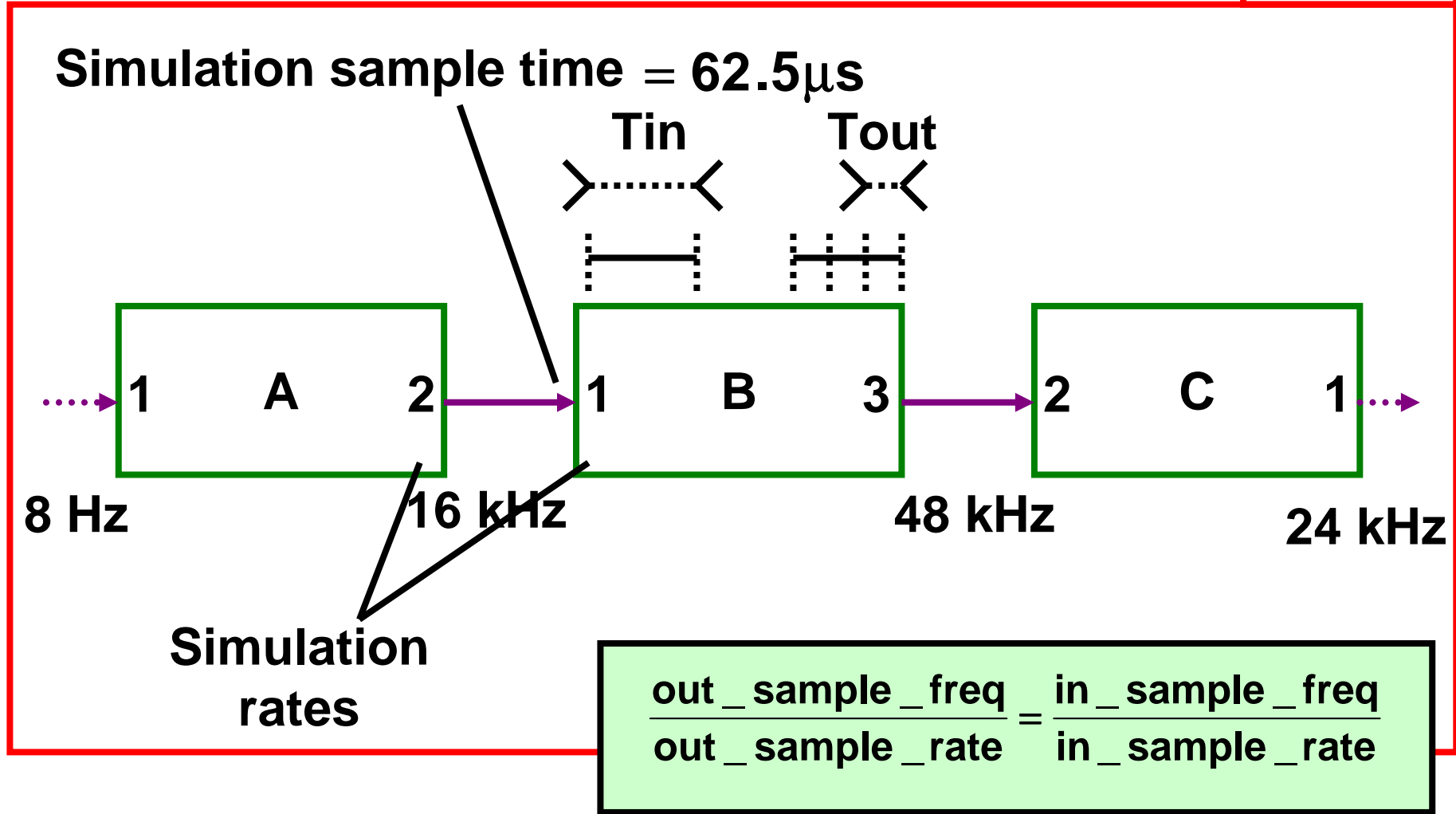

AMS Models : Integrator

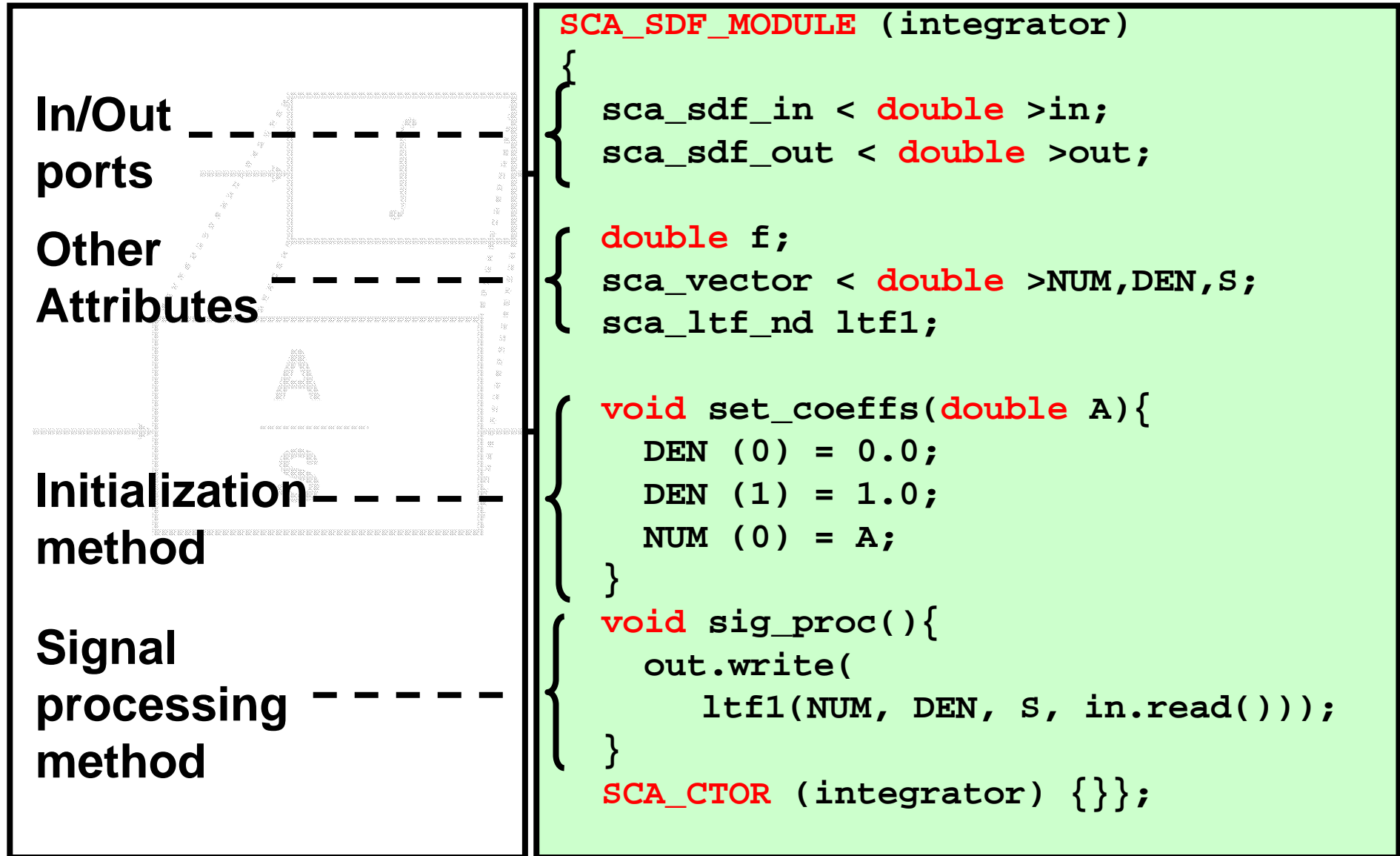

AMS models : Decimator

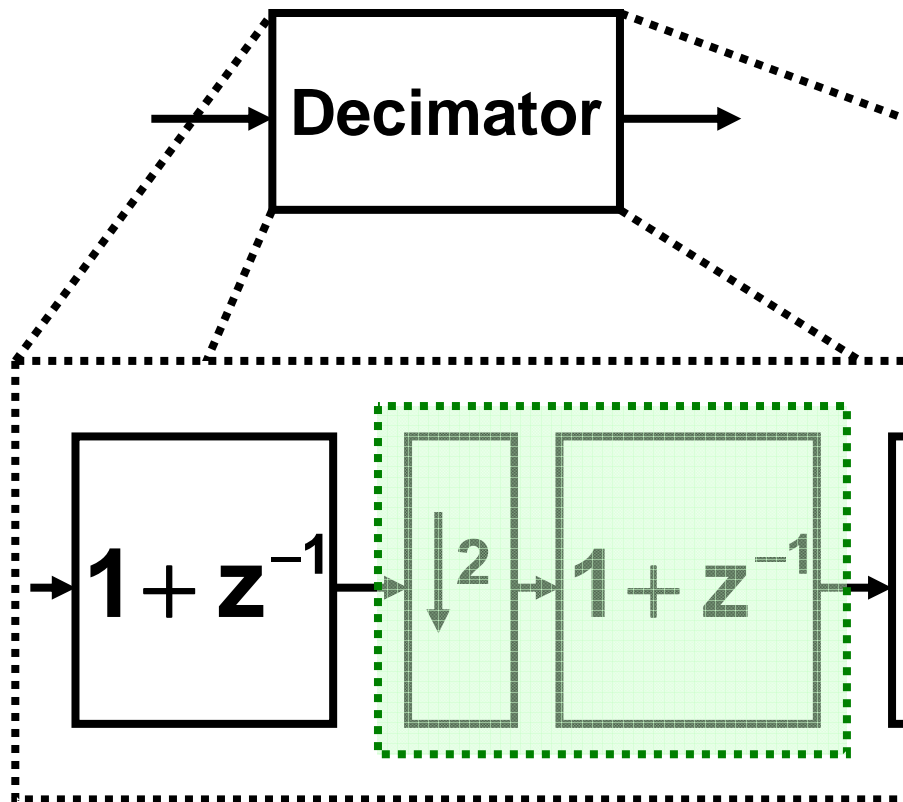

```
SCA_SDF_MODULE (decimator)
{
  sca_sdf_in < double >in;
  sca_sdf_out < double >out;

  double old_input;

  void init(){
    in.set_rate(2);
    out.set_rate(1);
    old_input=0;
  }
  void sig_proc(){
    double input=in.read(0)/2;
    out.write(old_input+input);
    old_input=input;
  }
  SCA_CTOR (decimator){}
};
```

RF models

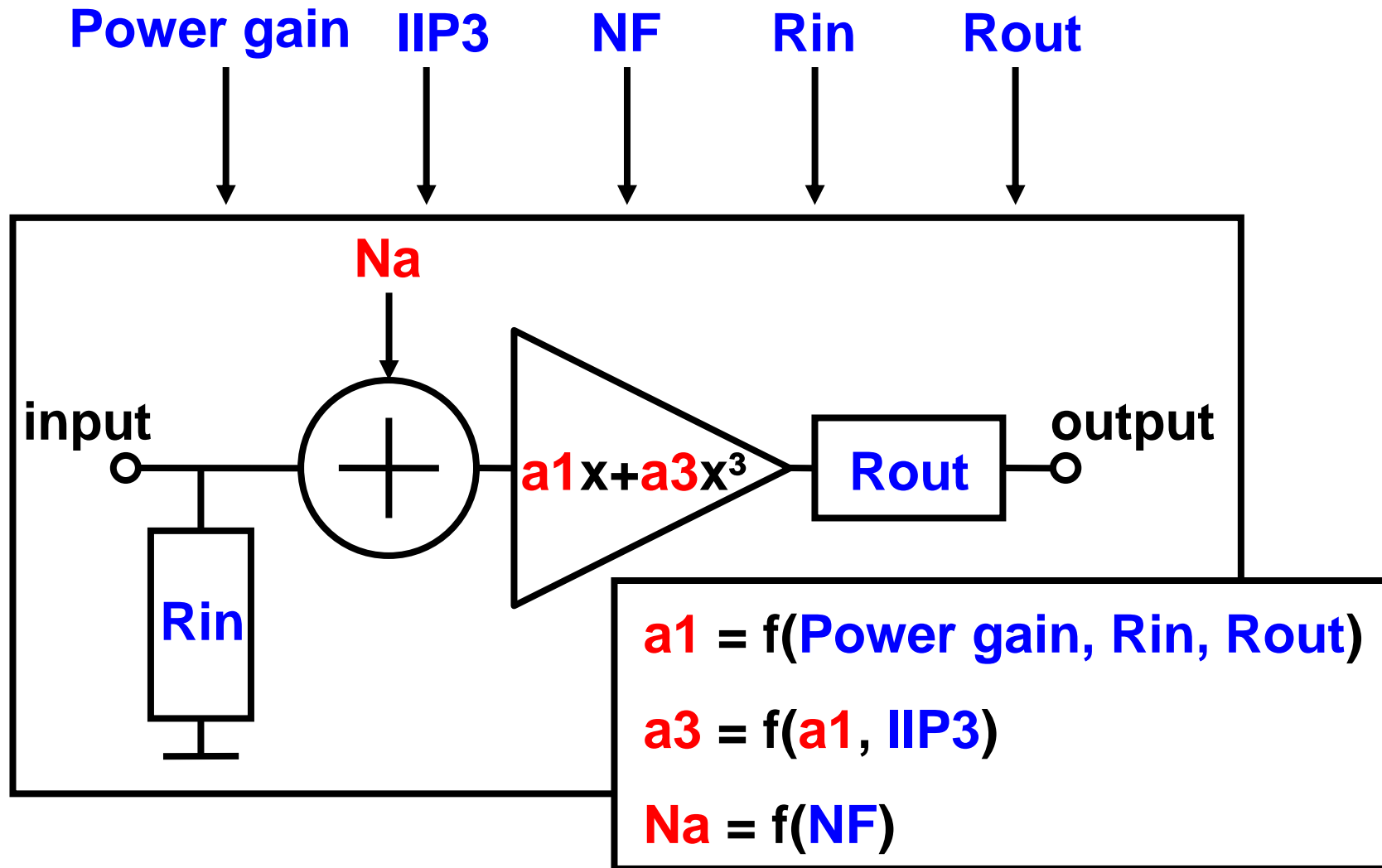

RF models : IIP3 and Noise Figure Test

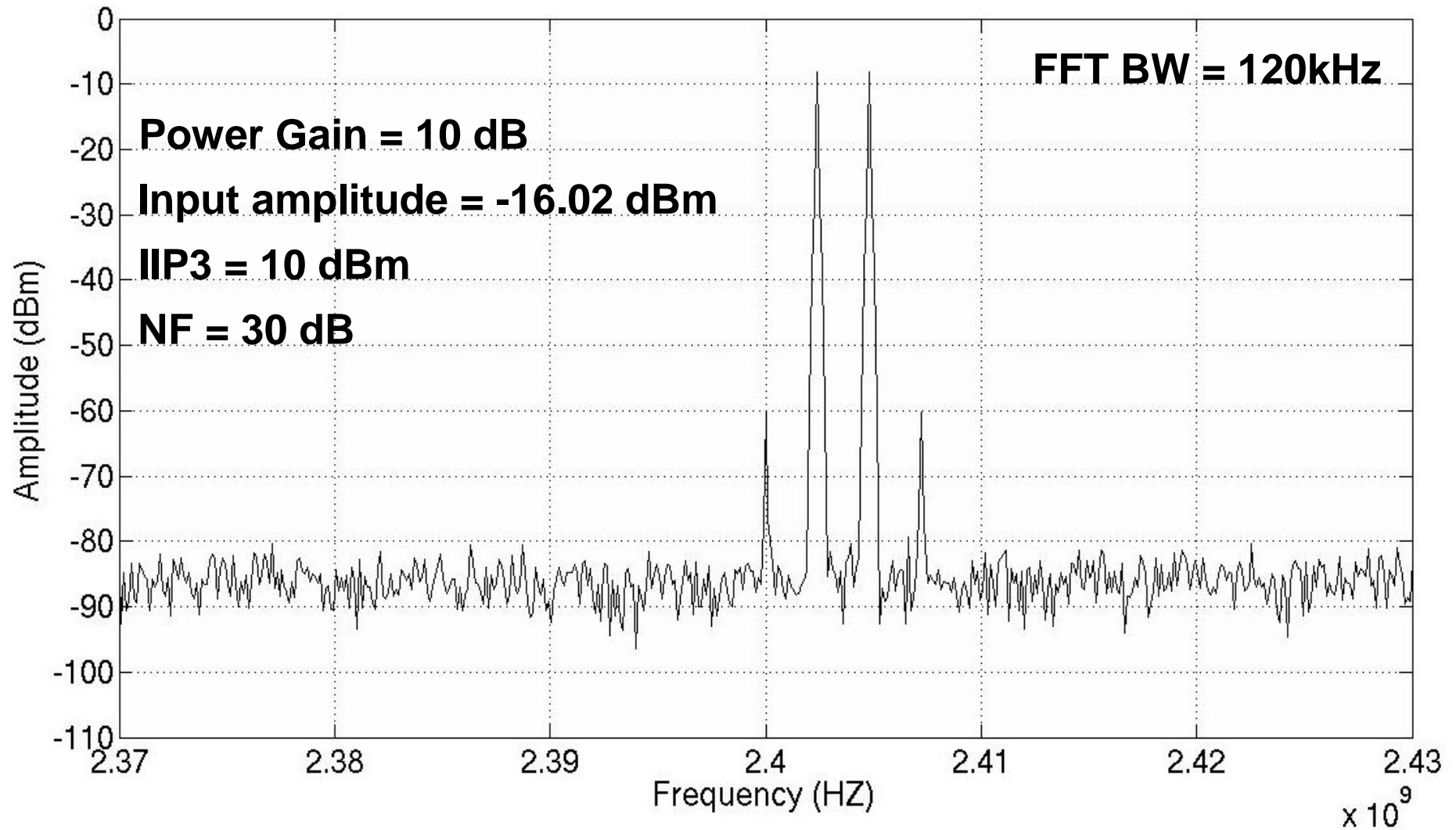

Wireless Sensor Network Node

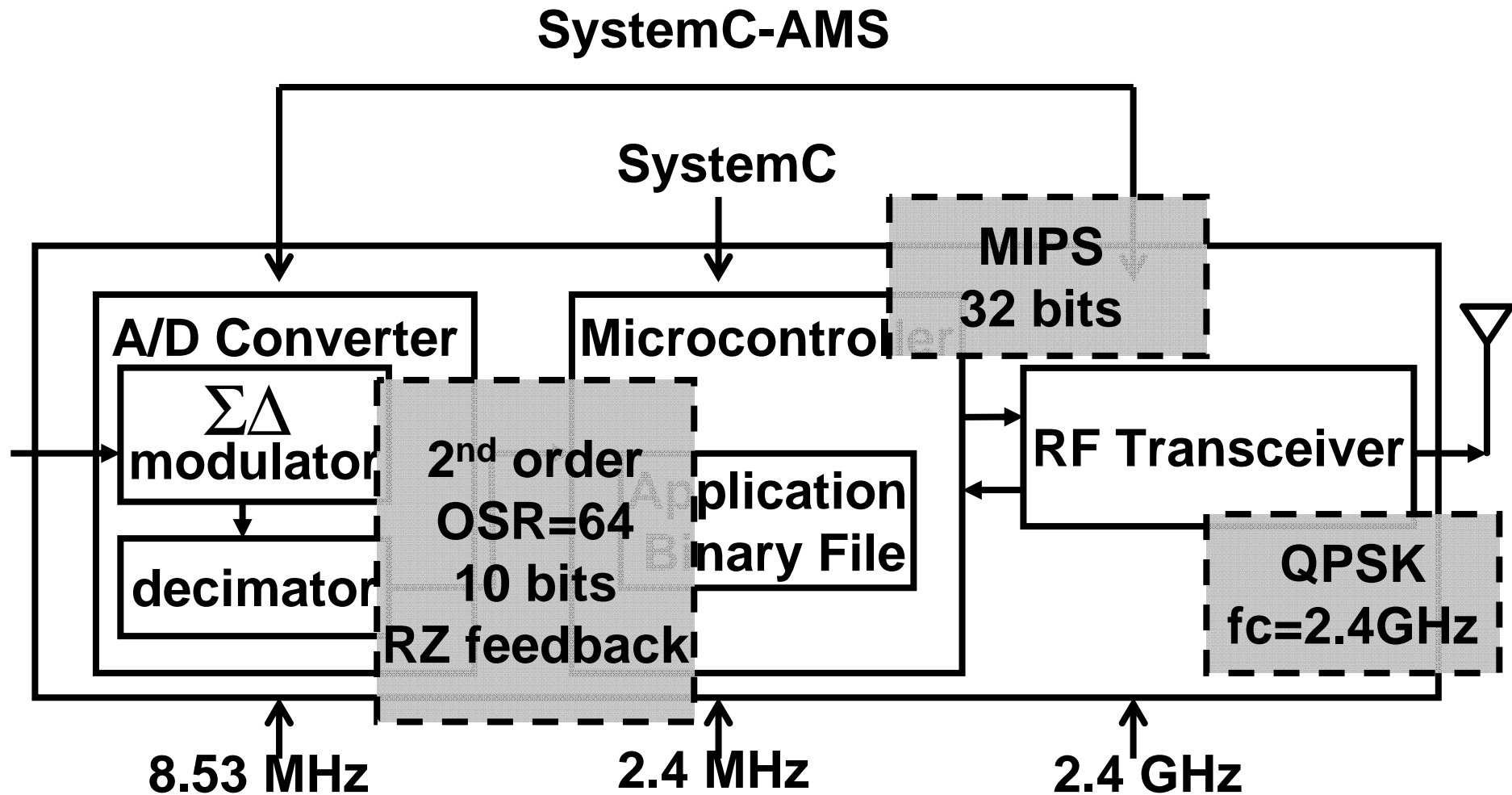

QPSK RF Transceiver

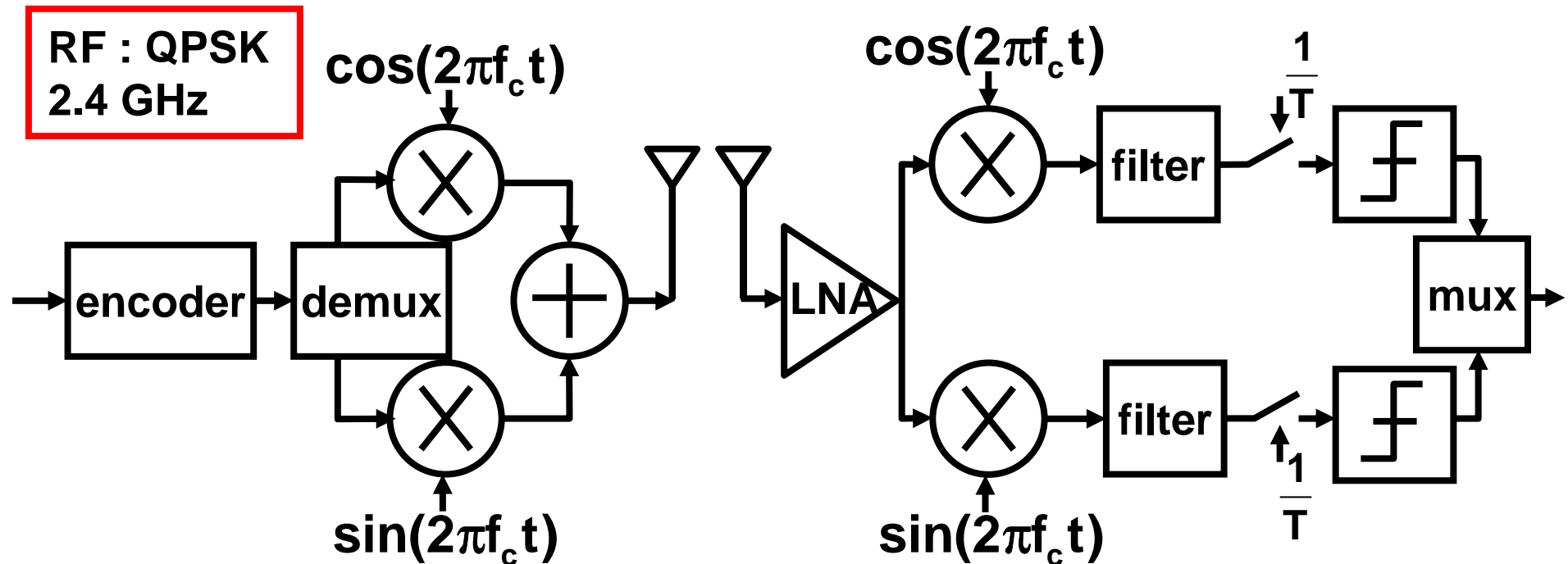

Taking Non-Idealities Into Account

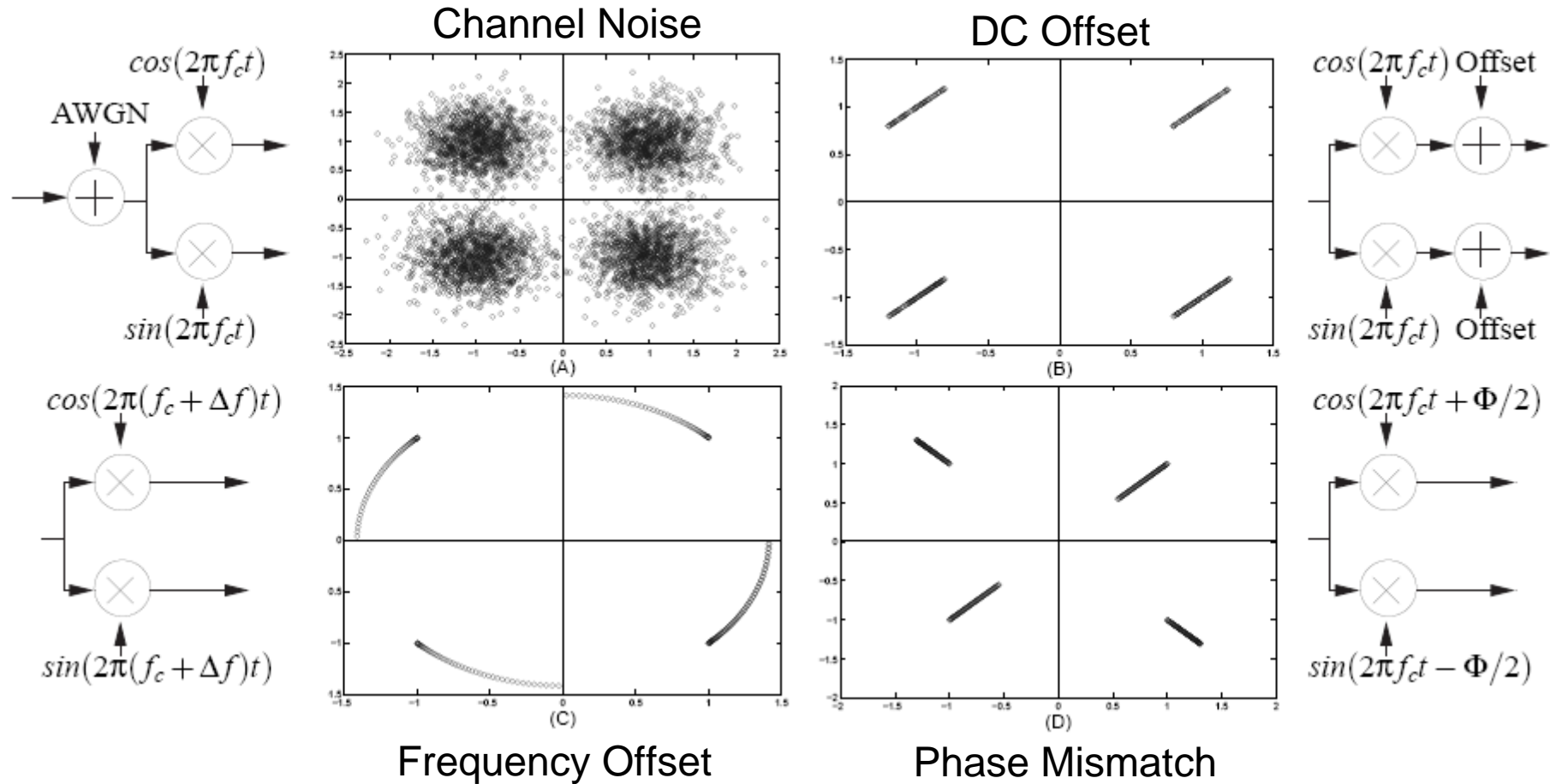

Bit Error Rate (BER)

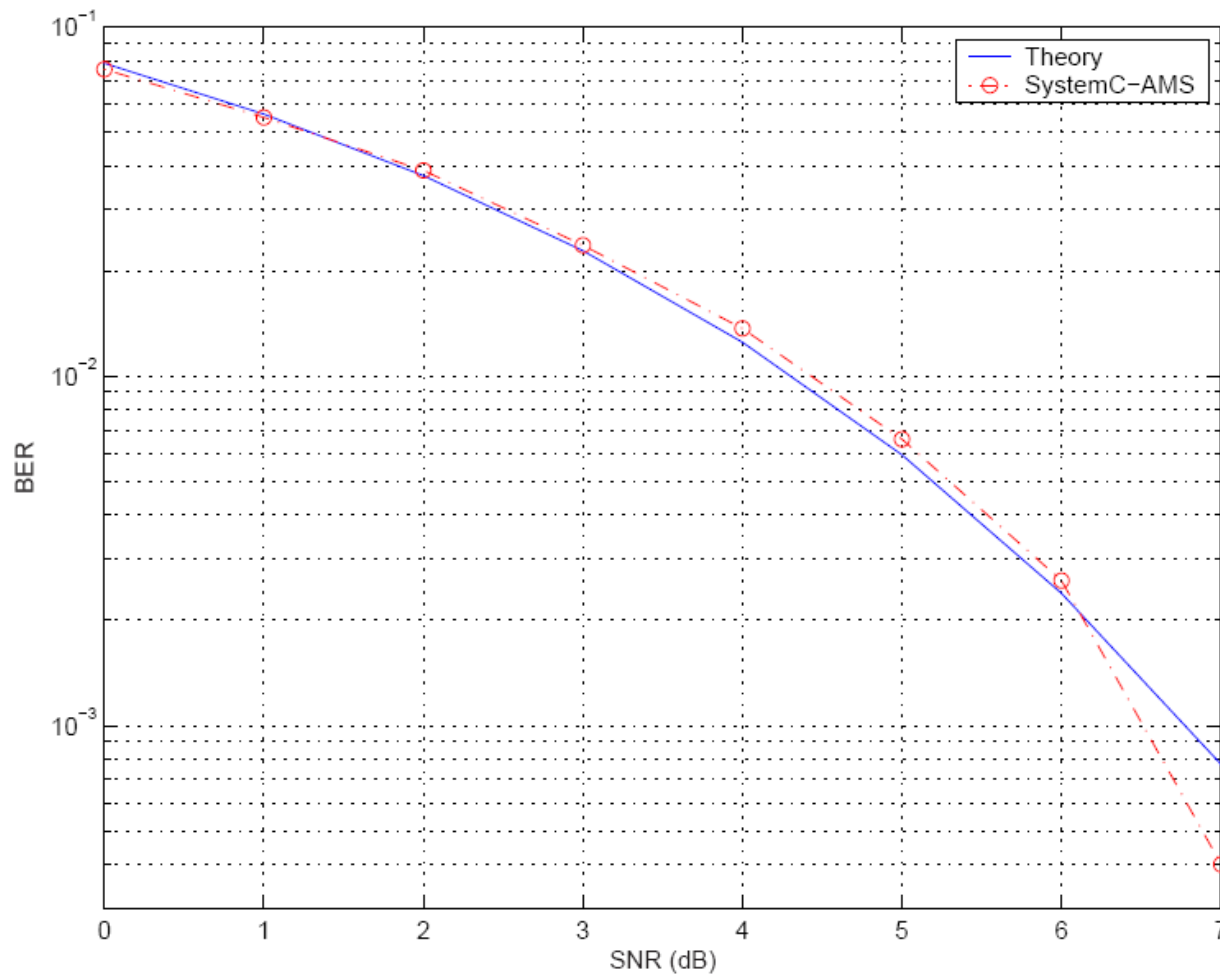

Outline

- Introduction
- SystemC-AMS Models
- Model Refinement Based on Transistor-Level Characterization
 - $\Sigma\Delta$ Analog-to-Digital Converter
- MEMS in SystemC-AMS
- Application: Wireless Seismic Sensor Network
- Conclusion

Conventional Analog Design Flow

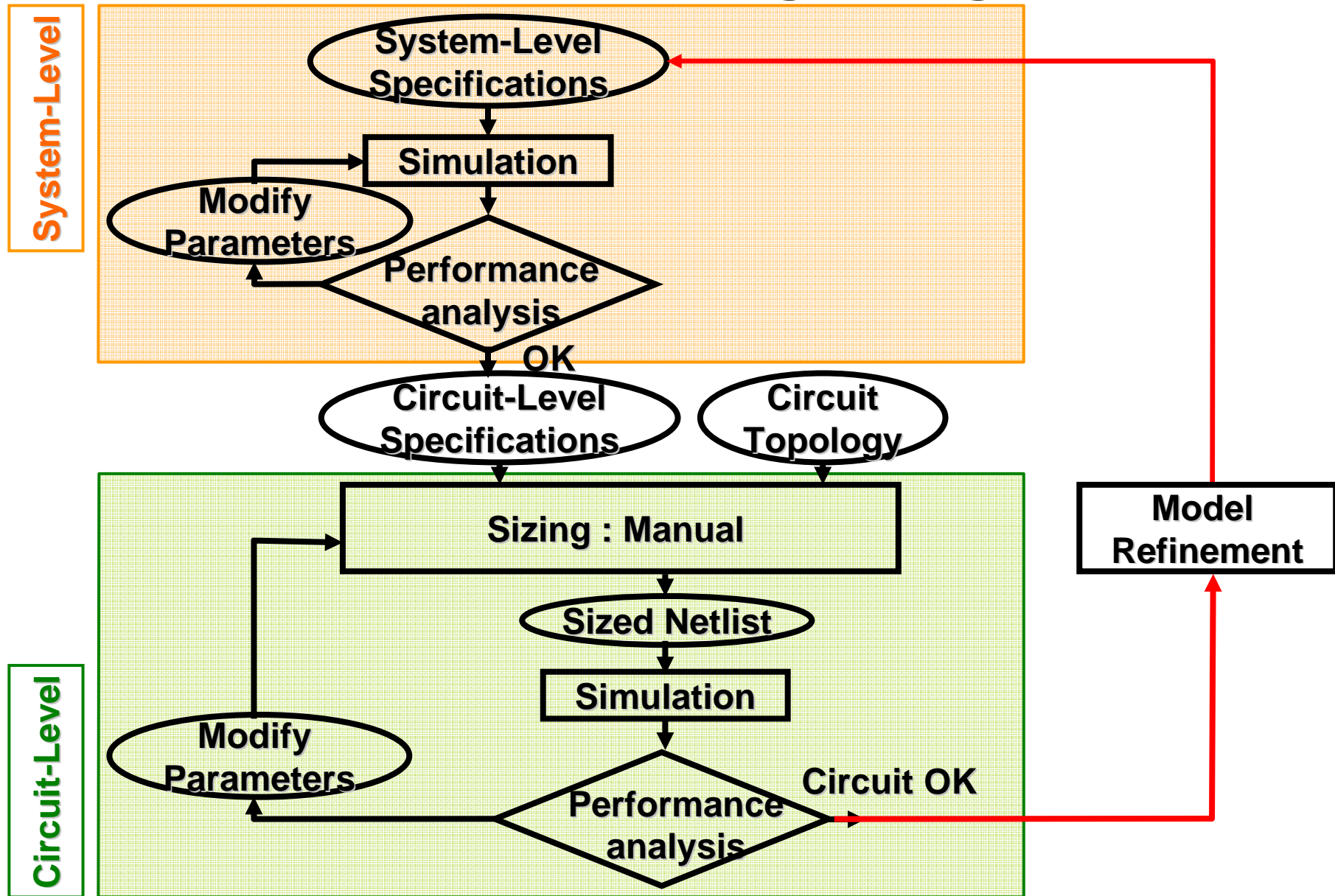

Continuous-Time $\Sigma\Delta$ Modulator

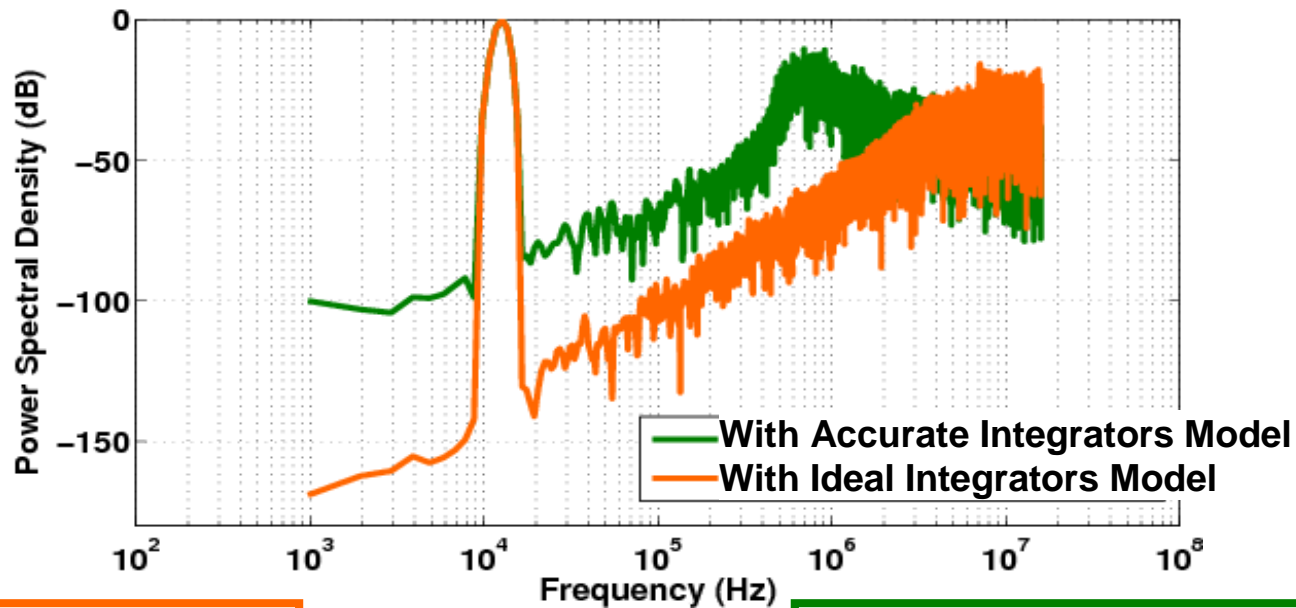
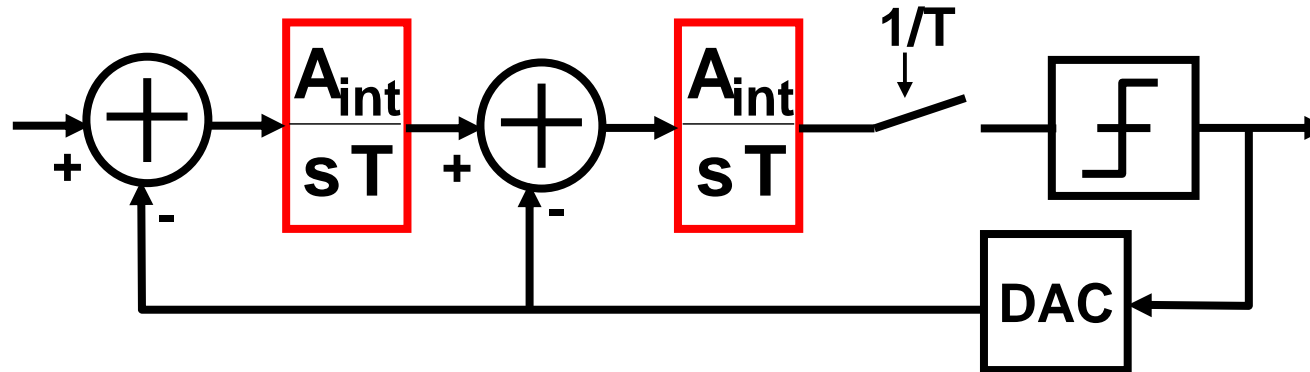

$$H(s) = \frac{A_{\text{int}}}{sT}$$

$$H(s) = K \frac{(1 + s/z_1)(1 + s/z_2)\dots}{(1 + s/p_1)(1 + s/p_2)\dots}$$

CMOS GmC Integrator

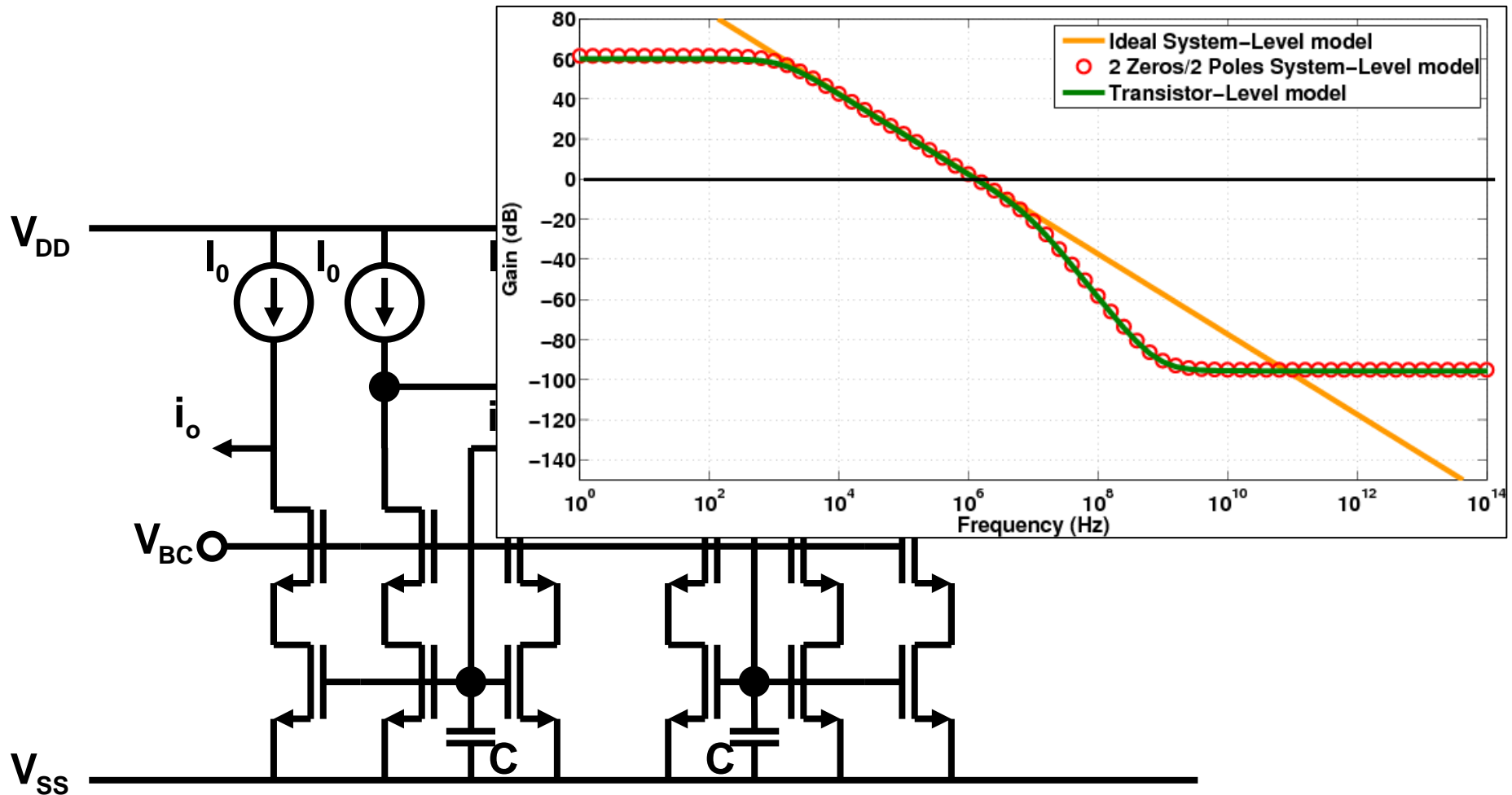

$$H(s) = K \frac{(1 + s/z_1)(1 + s/z_2)}{(1 + s/p_1)(1 + s/p_2)}$$

Characterization Flow : Conventional method

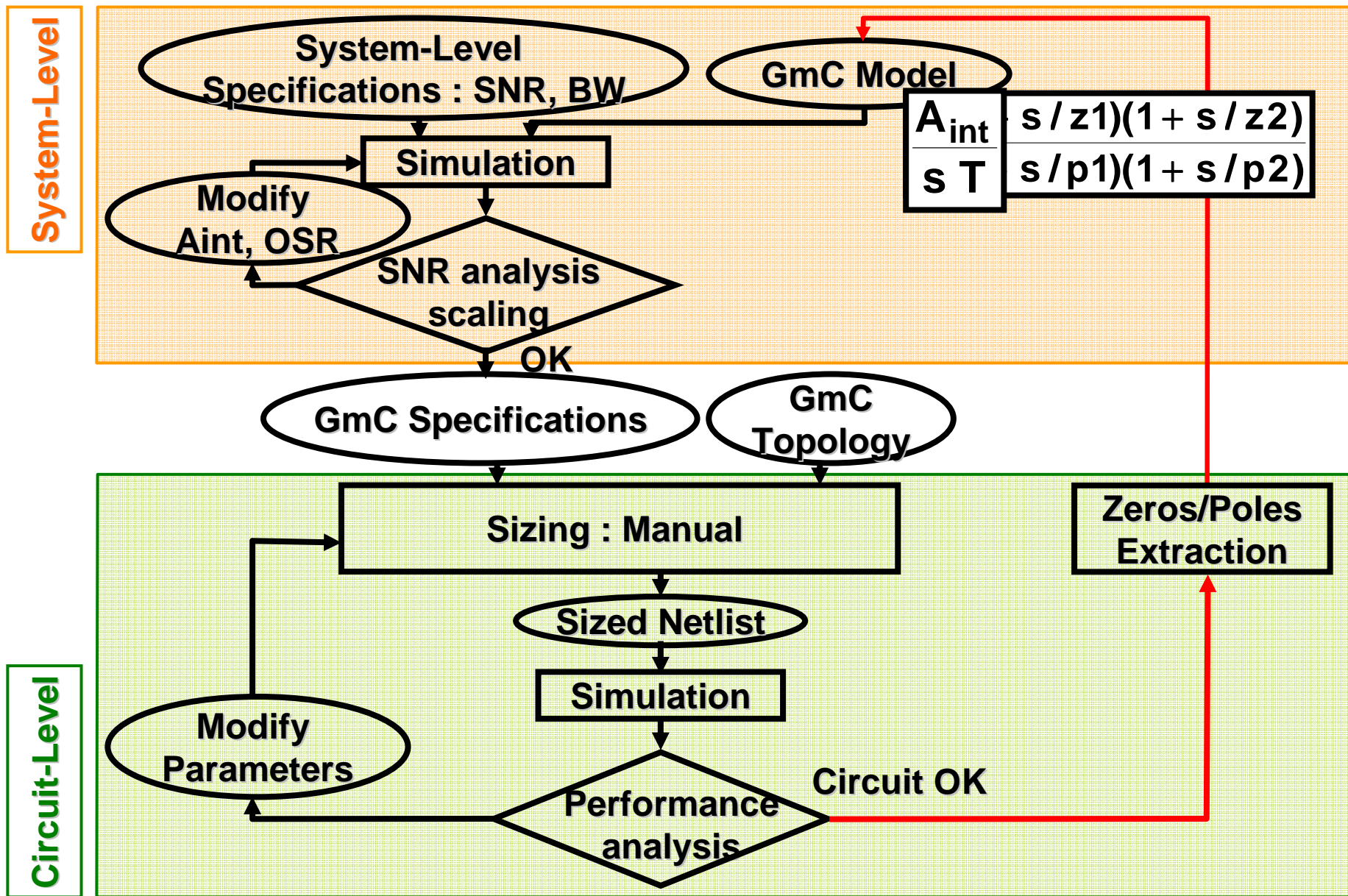

Characterization Flow : Proposed Method

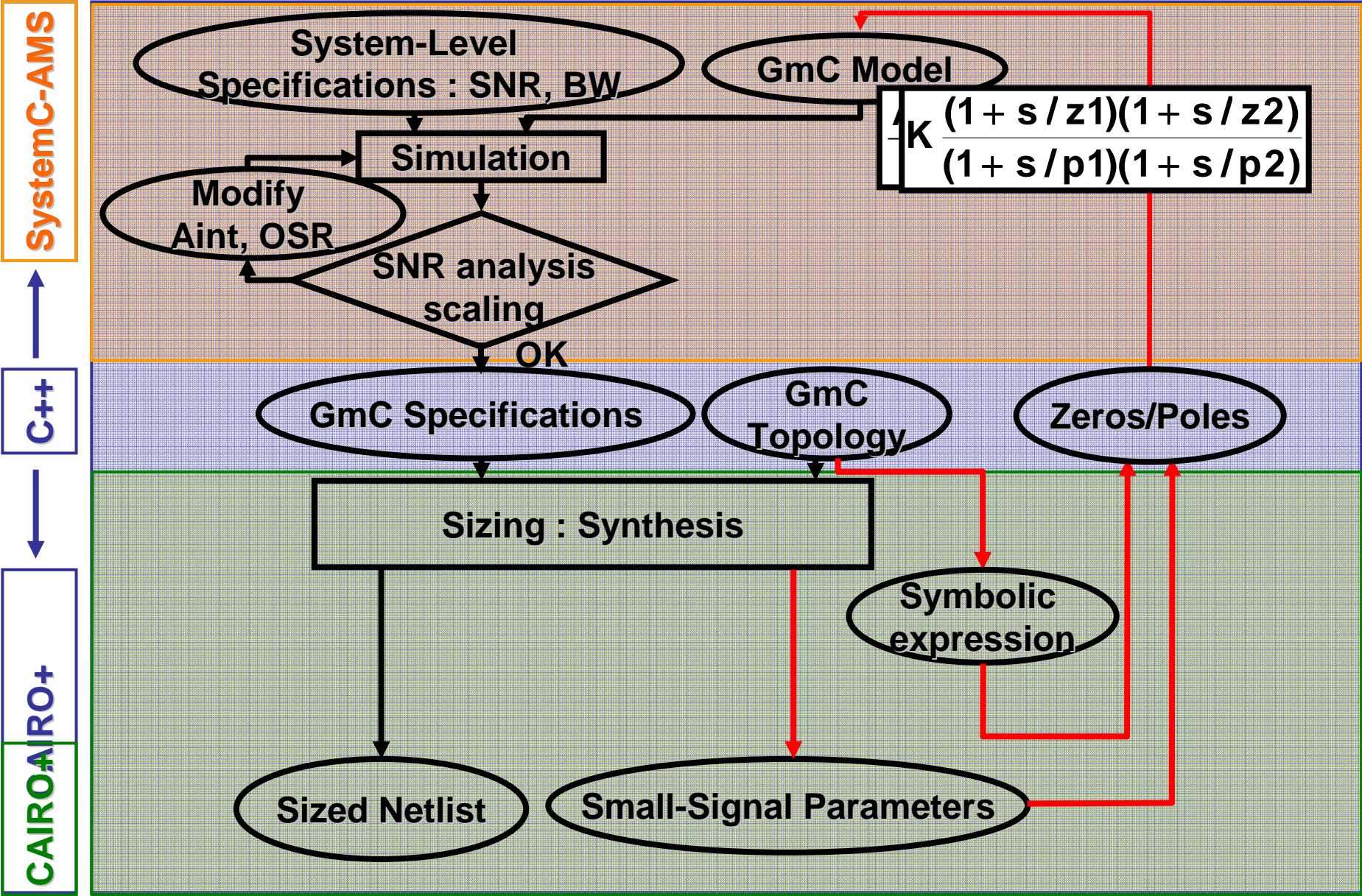

2nd order CT $\Sigma\Delta$ in a 0.13 μm CMOS

Specifications: SNR= 60 dB, OSR = 64, BW = 200 kHz

GmC Frequency Response

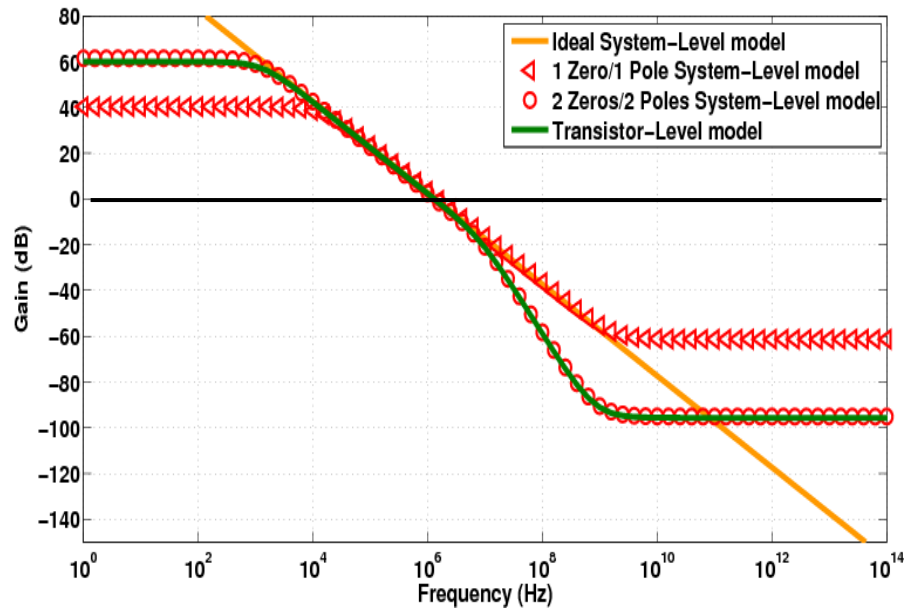

$\Sigma\Delta$ output Power Spectral Density

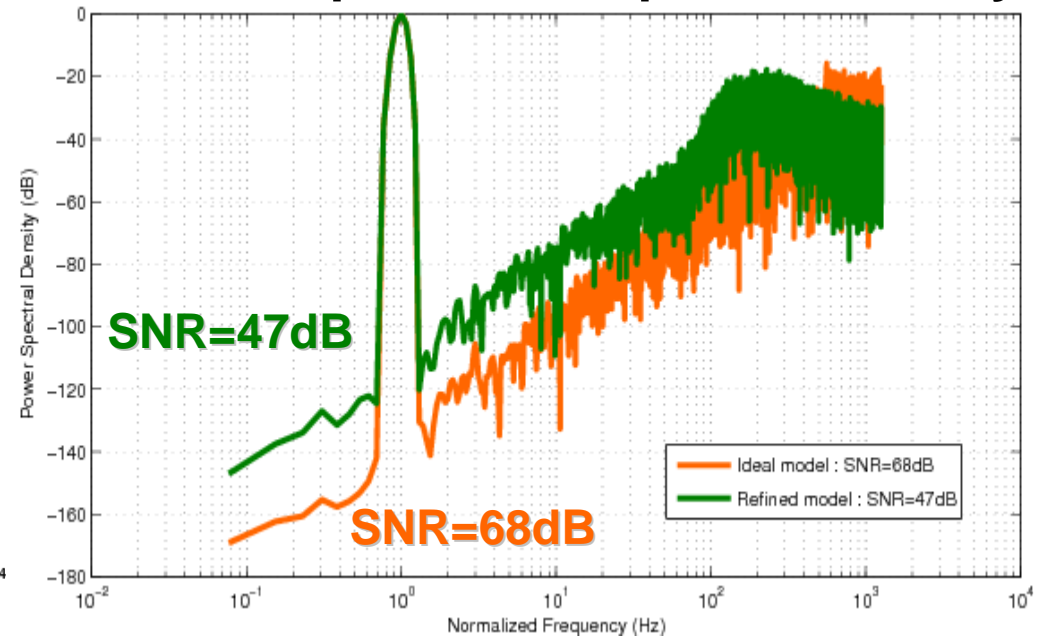

Transistors length: L1=10 μm , L3=9 μm

2nd order CT $\Sigma\Delta$ in a 0.13 mm CMOS

Specifications: SNR= 60 dB, OSR = 64, BW = 200 kHz

GmC Frequency Response

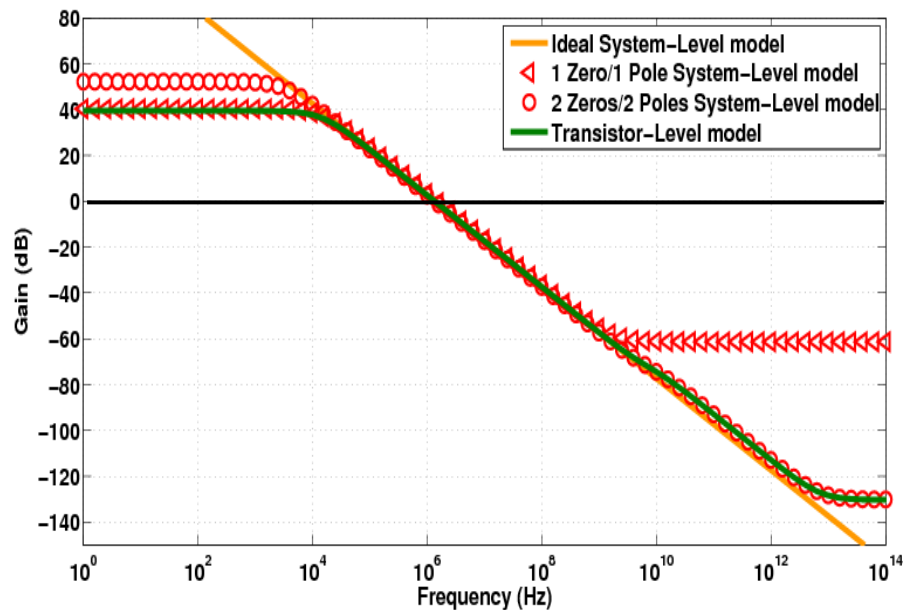

$\Sigma\Delta$ output Power Spectral Density

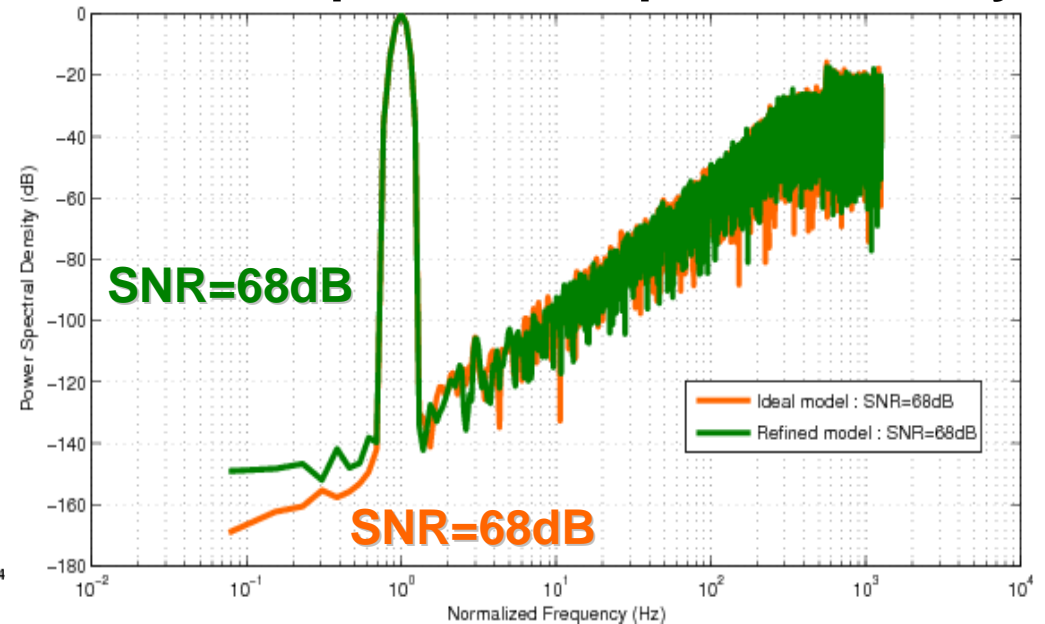

Transistors length: L1=3 μm , L3=0.18 μm

Outline

- Introduction
- SystemC-AMS Models
- Model Refinement Based on Transistor-Level Characterization
- **MEMS in SystemC-AMS**
 - Bandpass $\Sigma\Delta$ ADC with RF BAW resonator
- Application: Wireless Seismic Sensor Network
- Conclusion

Modulateur $\Sigma\Delta$

Conversion analogique => numérique

- Suréchantillonnage : $F_s \gg F_{Nyquist}$
- Mise en forme du bruit de quantification.

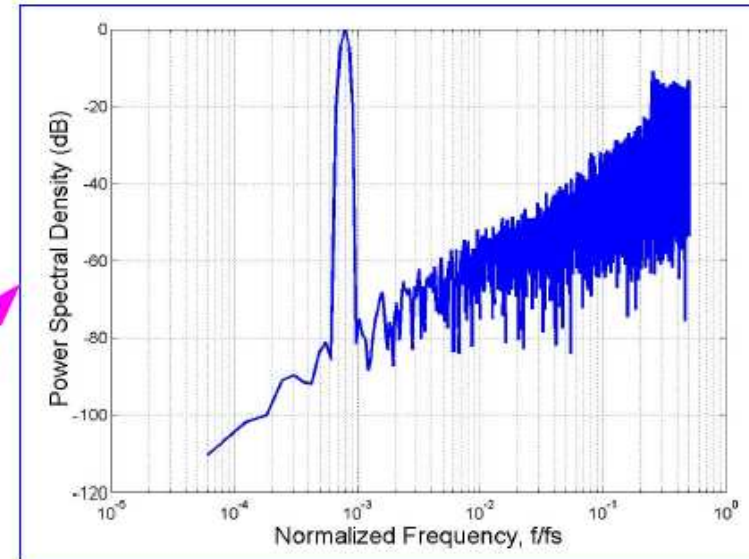
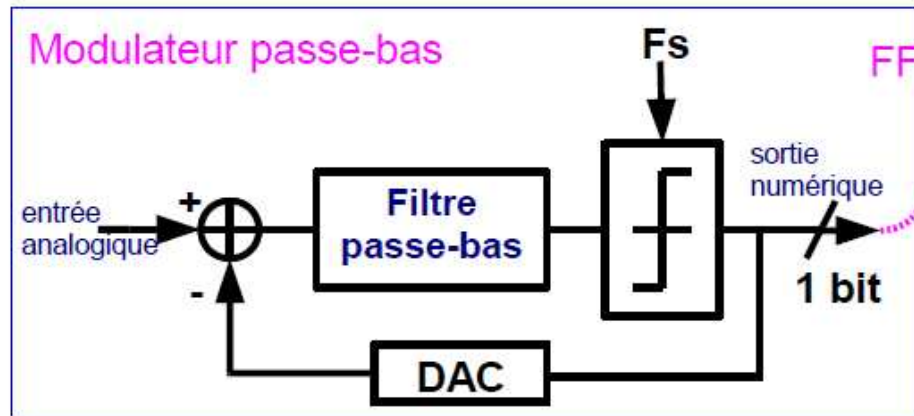

Modulateur $\Sigma\Delta$

Conversion analogique => numérique

- Suréchantillonnage : $F_s \gg F_{Nyquist}$
- Mise en forme du bruit de quantification.

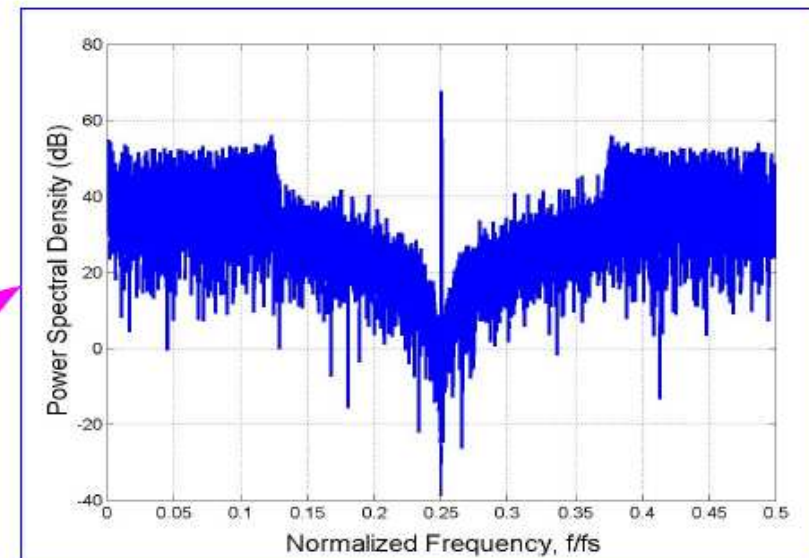
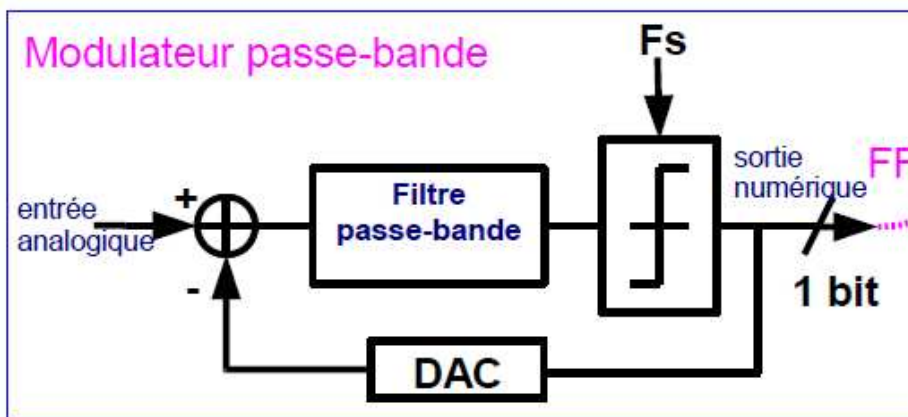
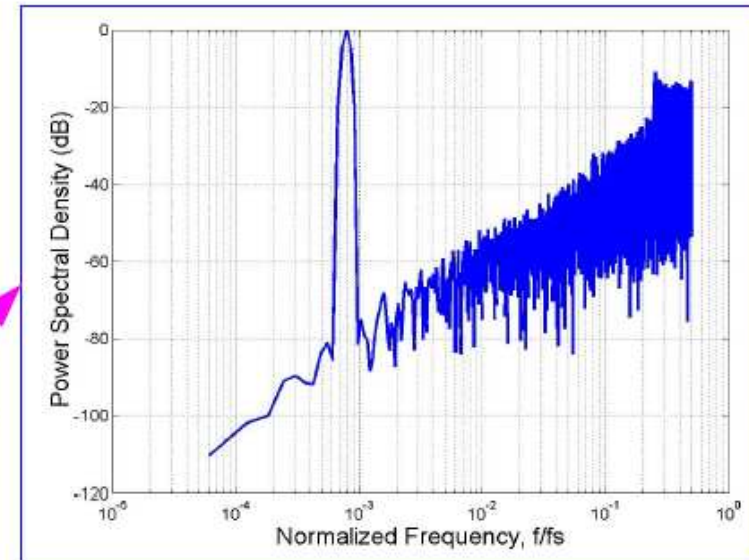
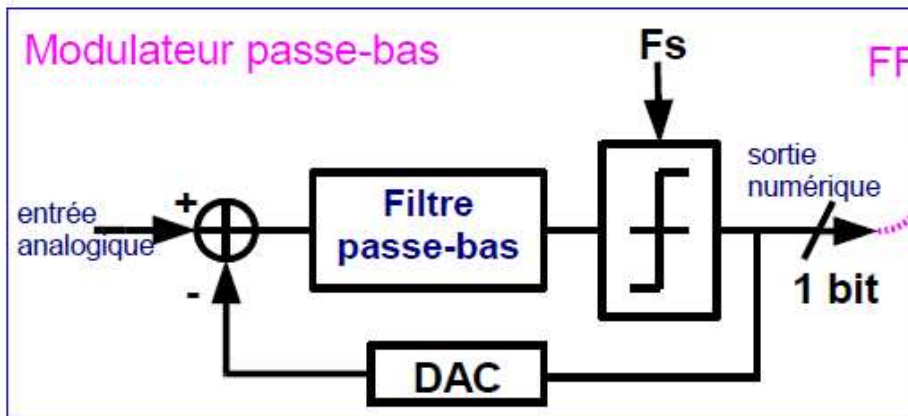

Récepteur RF avec modulateur $\Sigma\Delta$ passe-bande

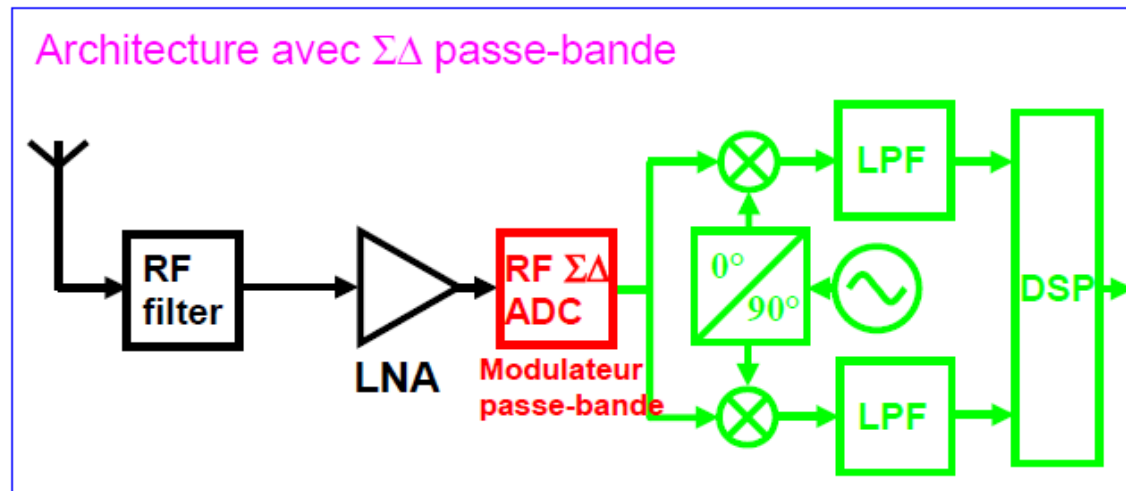
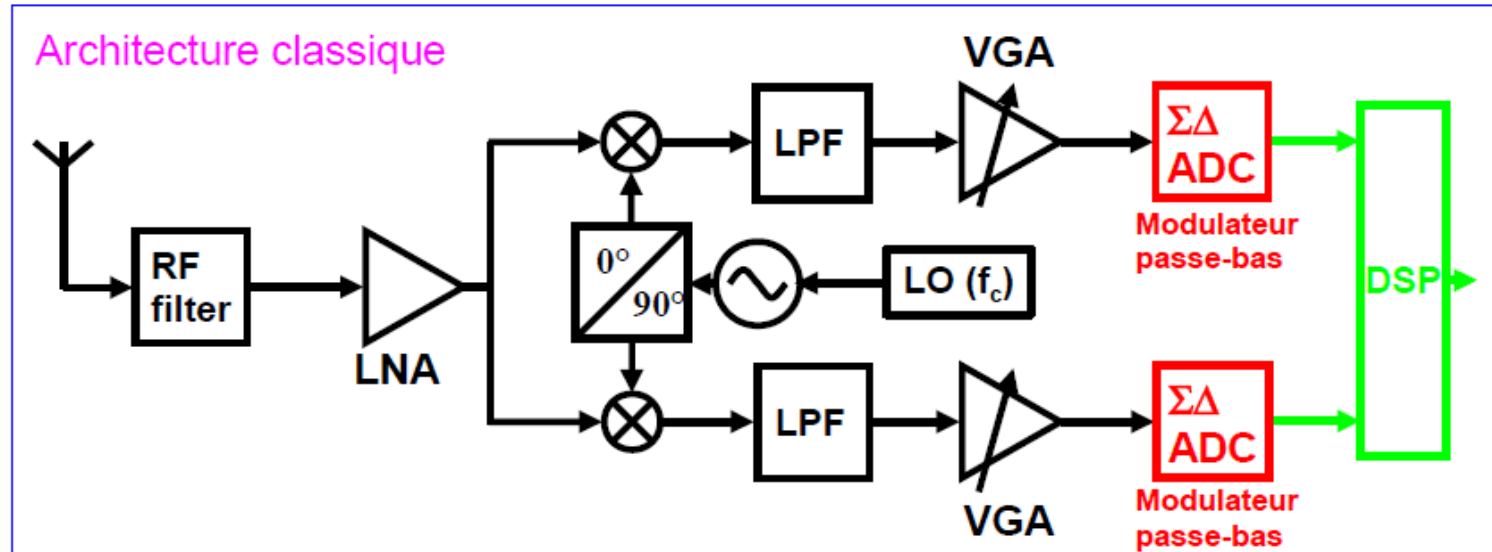

Objectif

Rapprocher l'ADC de l'antenne.

Avantage

Davantage d'opérations en numérique.

=> robuste, programmable.

Modulateur $\Sigma\Delta$ avec résonateur LC

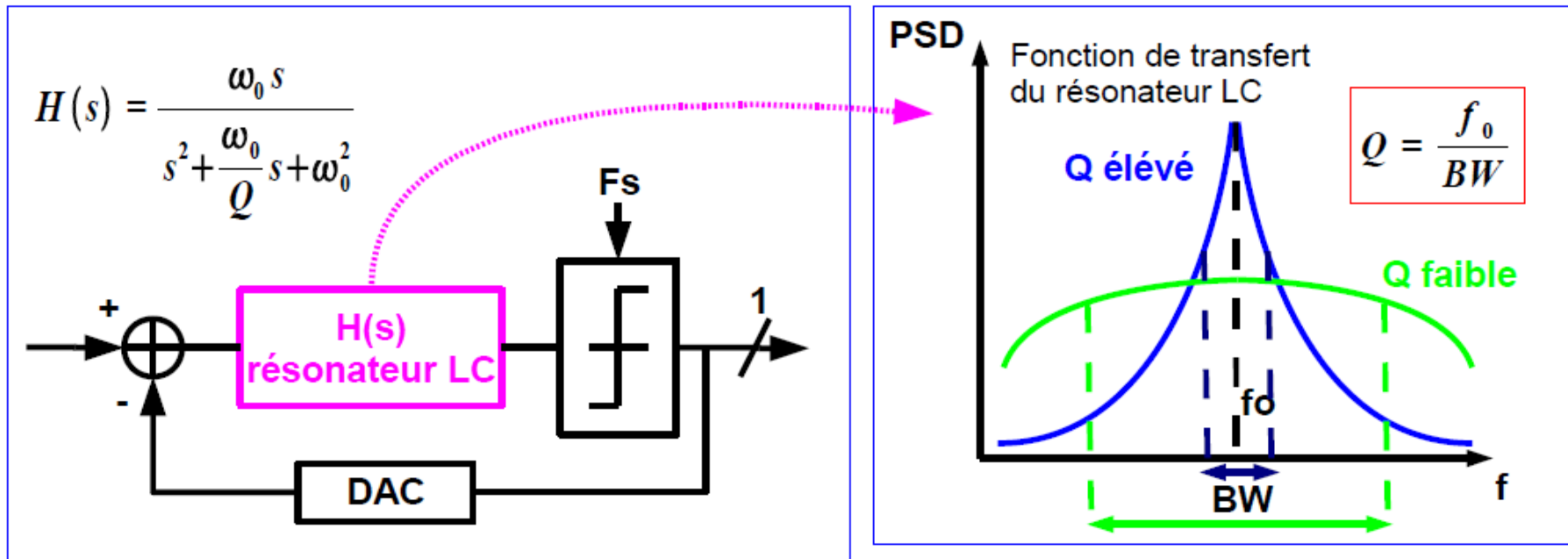

Les résonateurs LC intégrés ont un **facteur de qualité Q peu élevé** (Q=10).

Problème : facteur de qualité bas

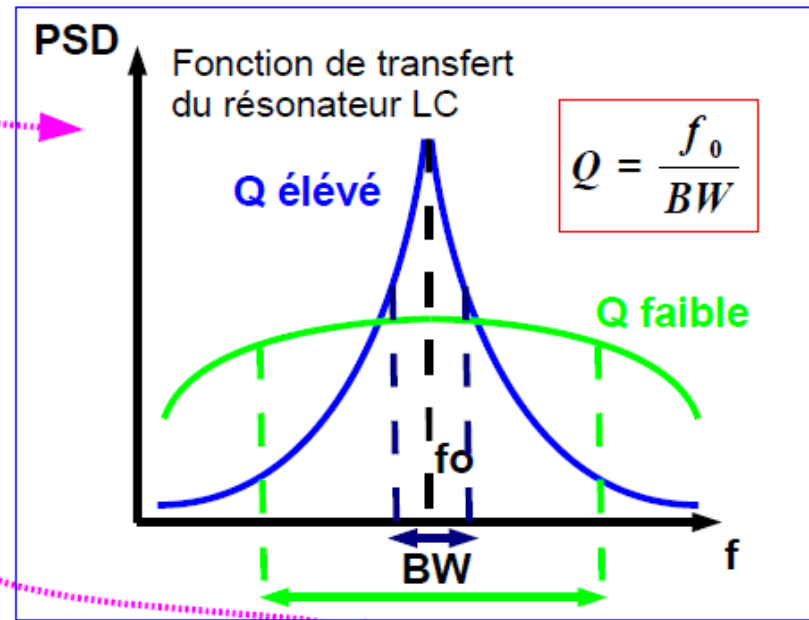
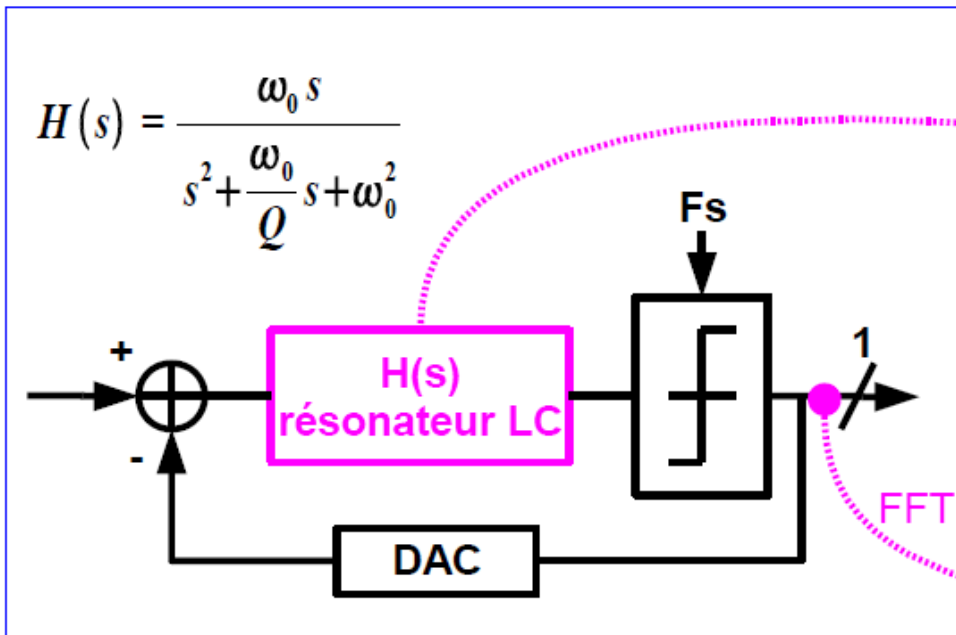

Les résonateurs LC intégrés ont un **facteur de qualité Q peu élevé** (Q=10).

Problème : $Q \downarrow \Rightarrow SNR \downarrow \Rightarrow \text{résolution} \downarrow$

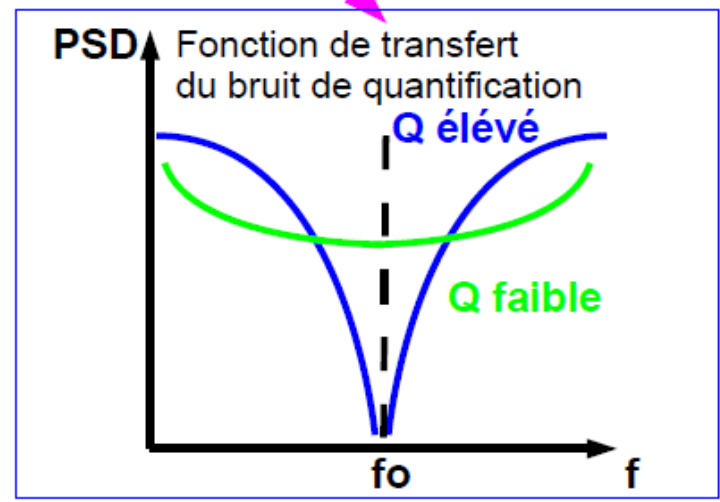

Résonateur électromécanique BAW

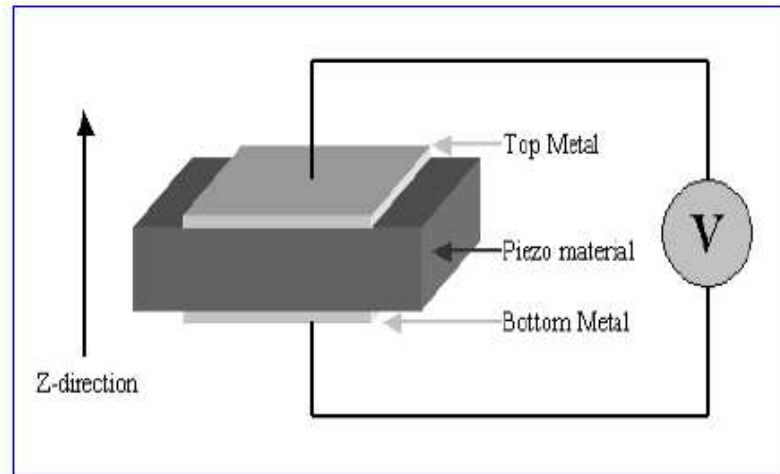

BAW = Bulk Acoustic Wave

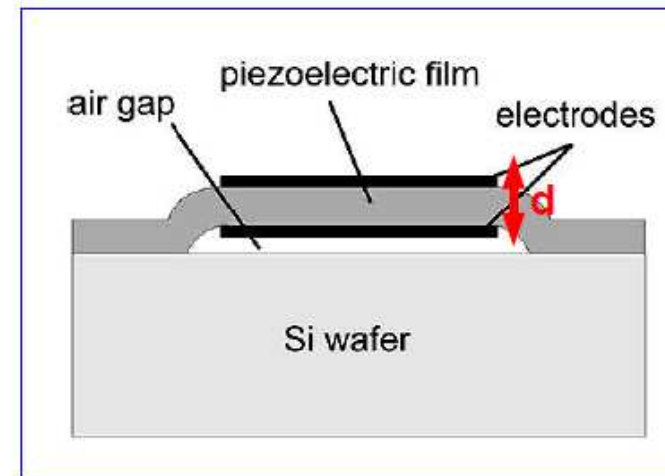

Avantages : - facteur de qualité élevé (plusieurs milliers).
- composant intégrable (compatible CMOS).

Modulateur $\Sigma\Delta$ avec résonateur BAW

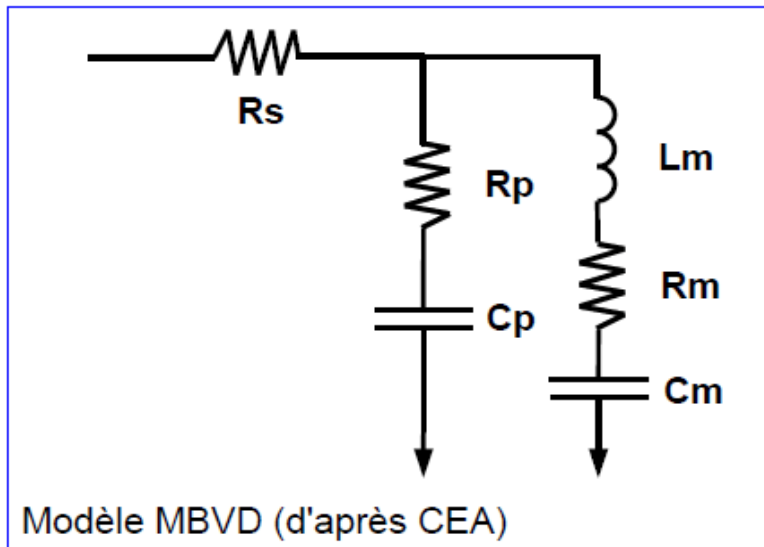
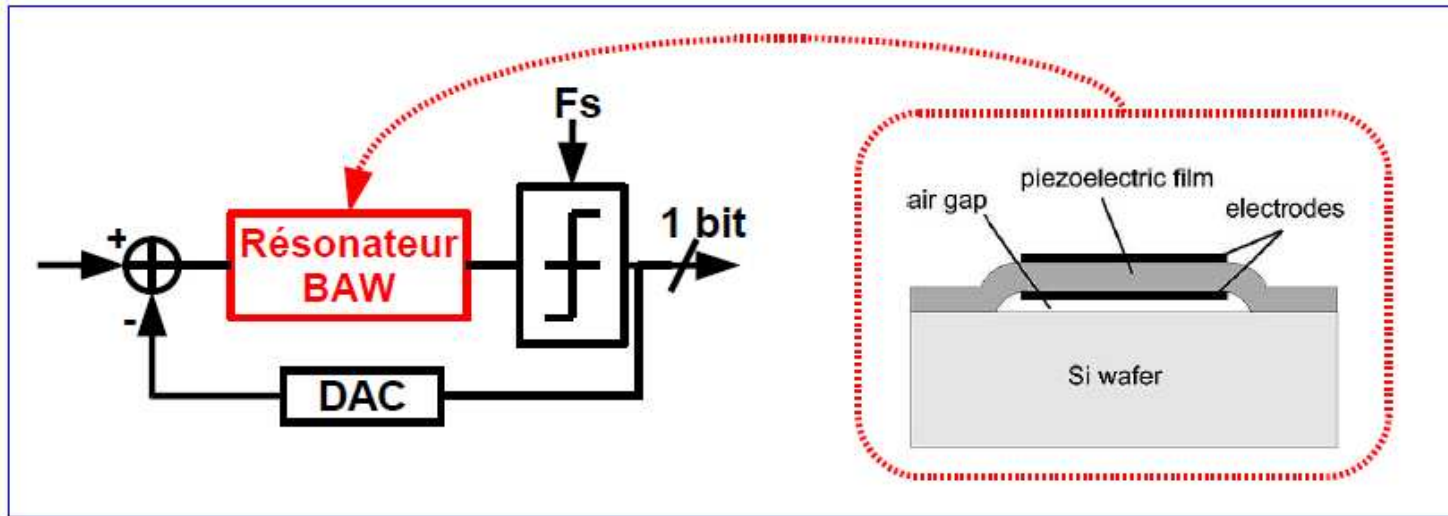

Impédance $Z(s)$

$$Z(s) = \frac{K}{s} \frac{s^2 + \frac{\omega_s}{Q_{S0}} s + \omega_s^2}{s^2 + \frac{\omega_p}{Q_{P0}} s + \omega_p^2}$$

La réponse en fréquence: résonateur LC vs BAW

$$H_{LC}(s) = \frac{\omega_0 s}{s^2 + \omega_0^2}$$

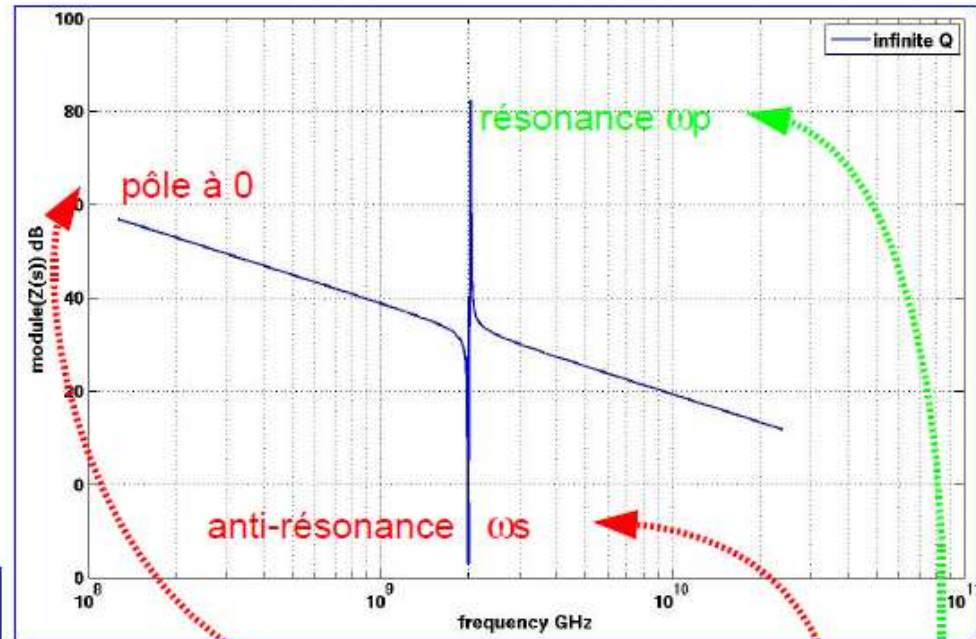
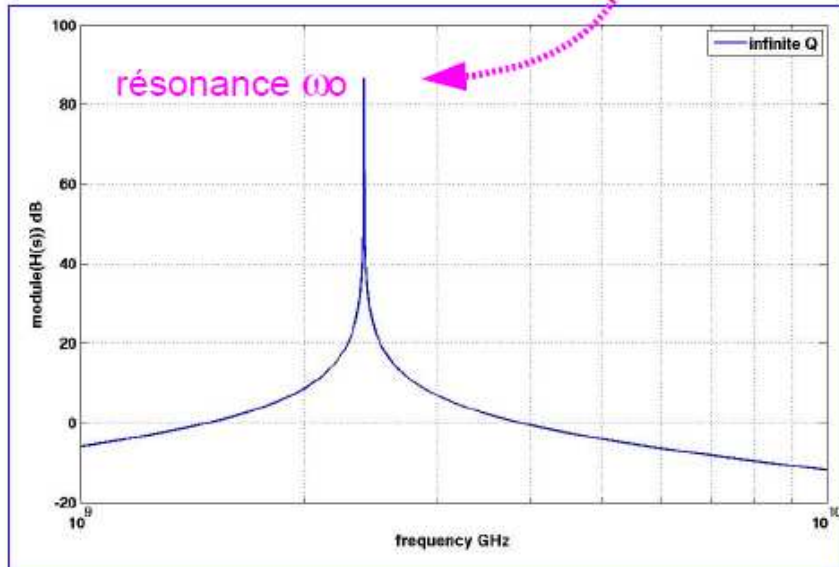

$$H_{BAW}(s) = \frac{K}{s} \frac{s^2 + \omega_S^2}{s^2 + \omega_P^2}$$

Annulation de l'anti-résonance

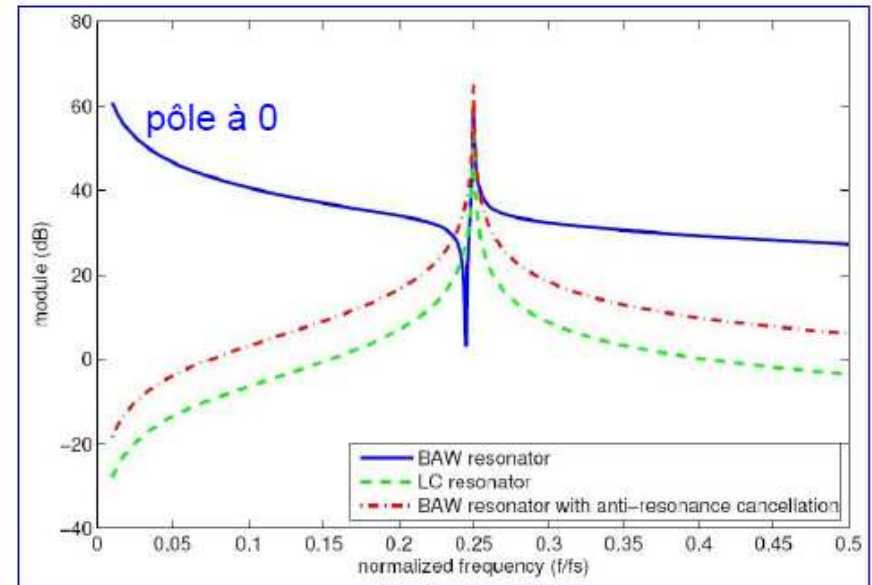
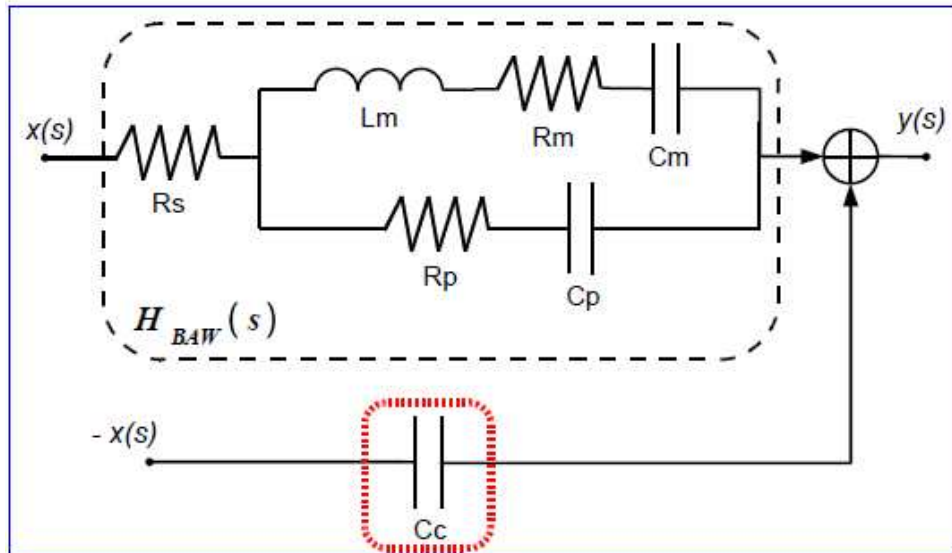

Modulateur $\Sigma\Delta$ BAW avec annulation de l'anti-résonance

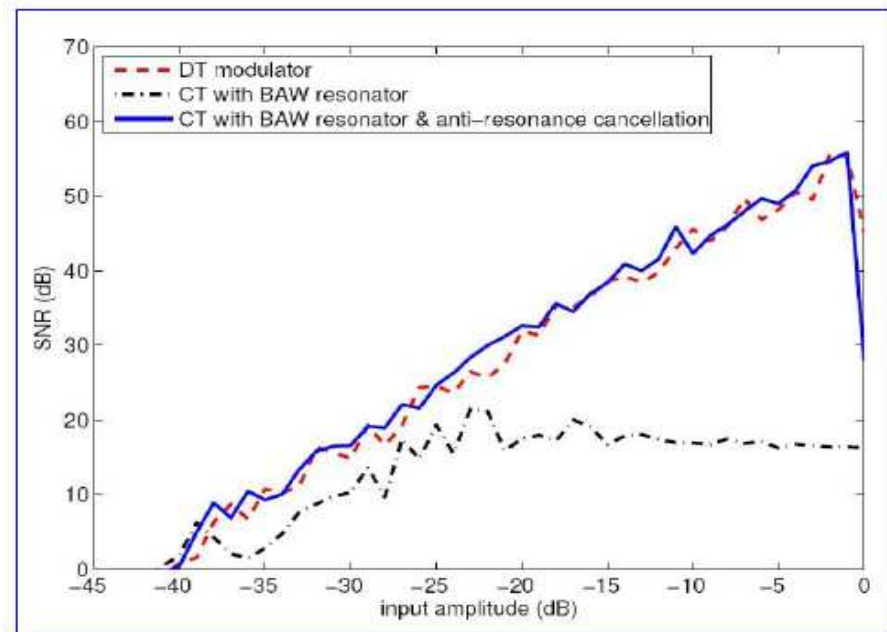
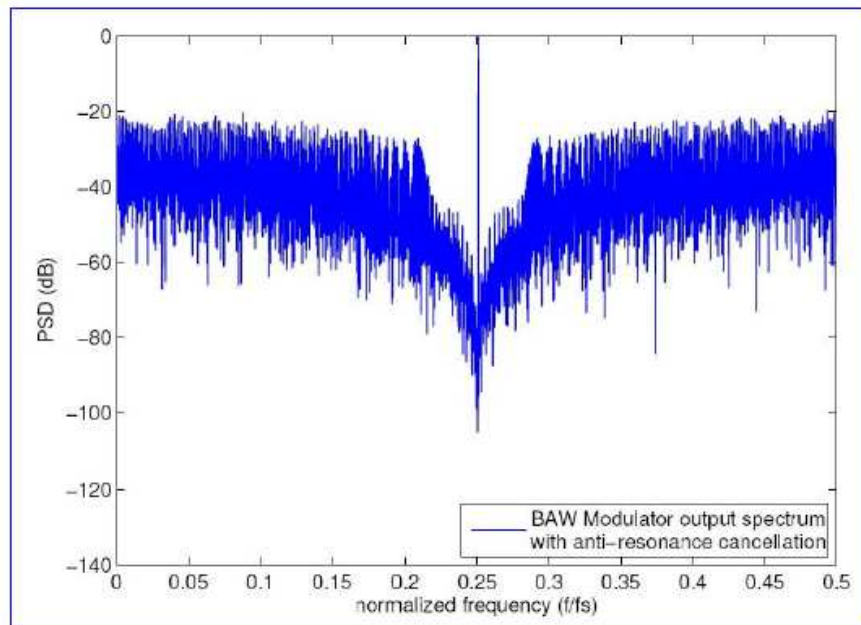
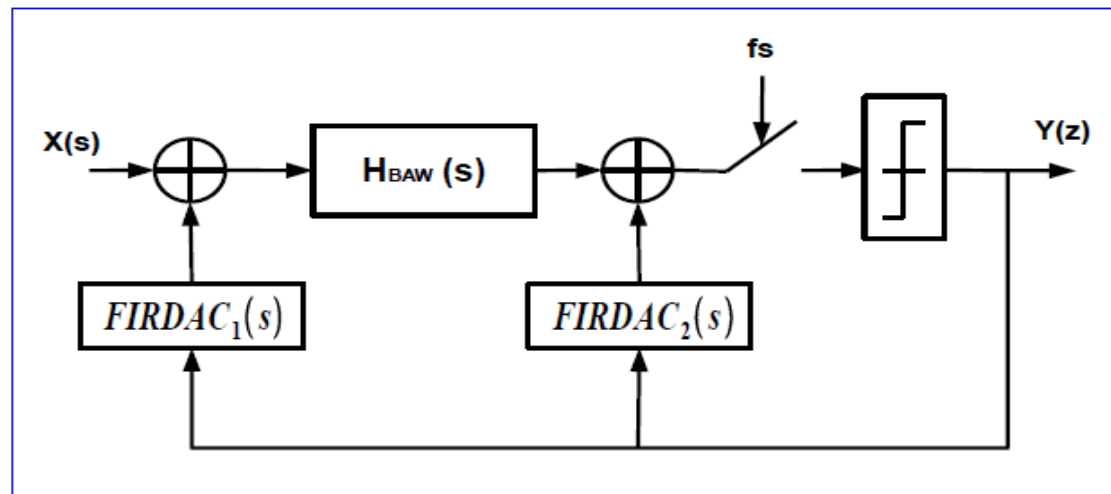

Outline

- **Introduction**
- **SystemC-AMS Models**
- **Model Refinement Based on Transistor-Level Characterization**
- **MEMS in SystemC-AMS**
- **Application: Wireless Seismic Sensor Network**
- **Conclusion**

4. Wireless Sensor Network Node

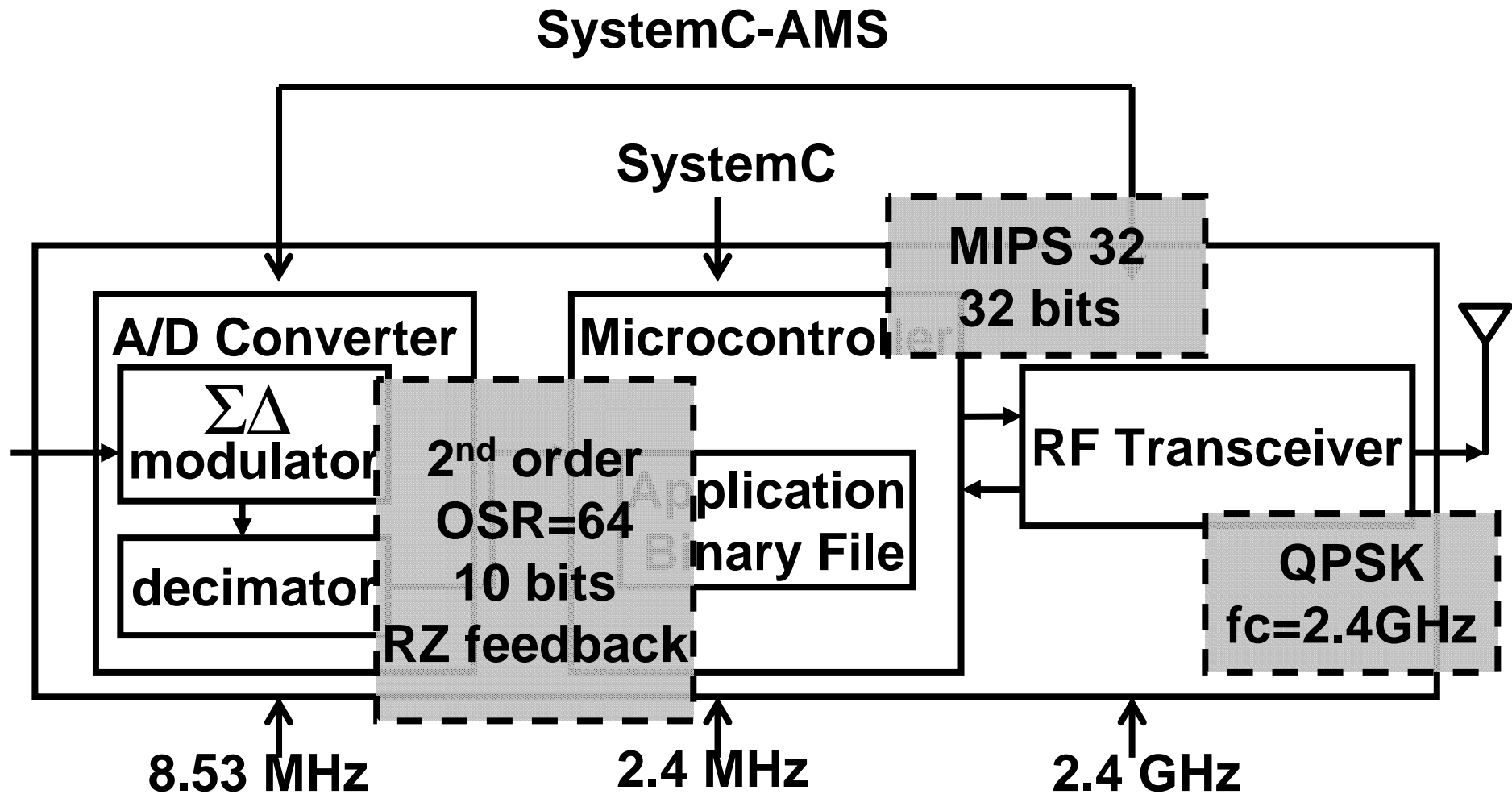

Wireless Seismic Sensor Network

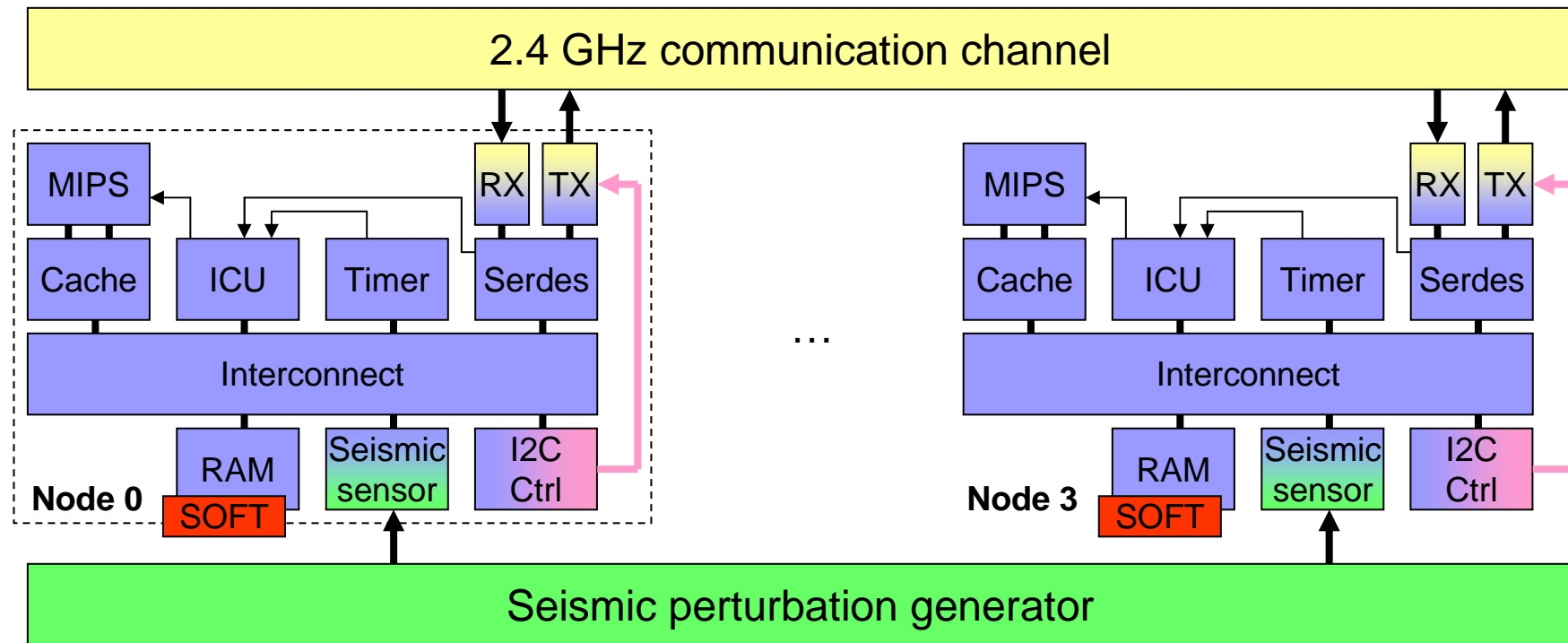

- Digital, BCA, SocLib
- Analog, SystemC-AMS TDF, RF
- Analog, SystemC-AMS TDF, Physics, $\Sigma\Delta$
- Analog, SystemC-AMS ELN, Electrical, Bus
- Embedded software

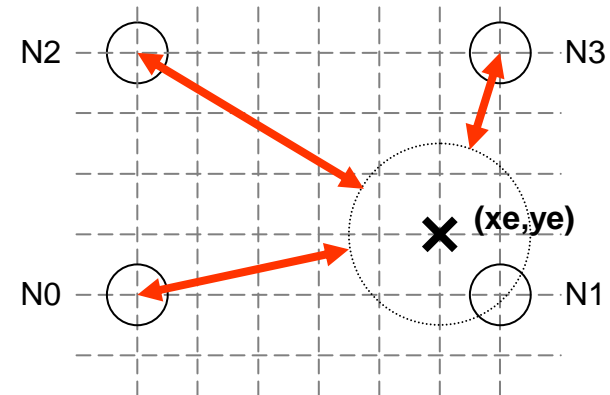

Geometry (1)

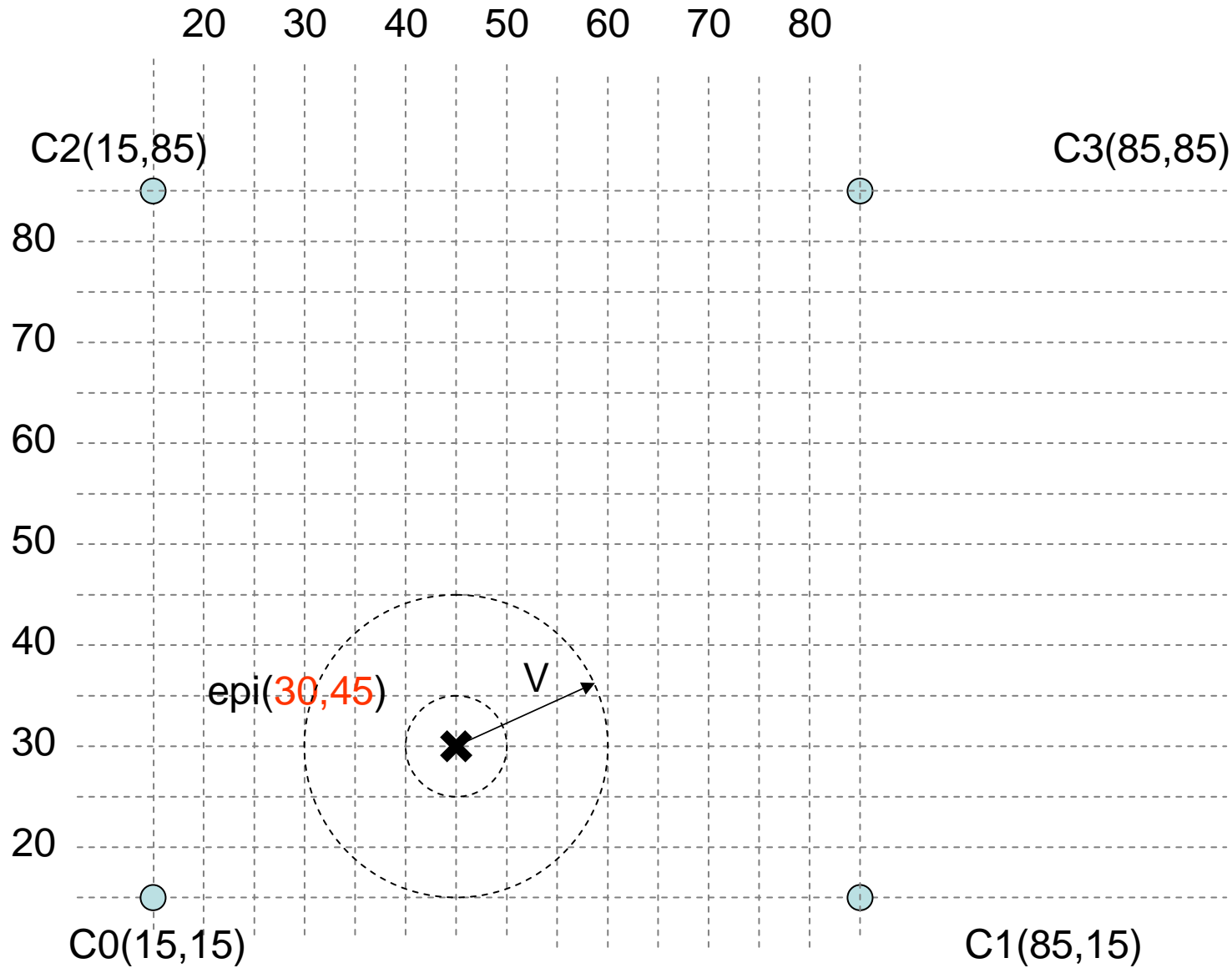

Geometry (2)

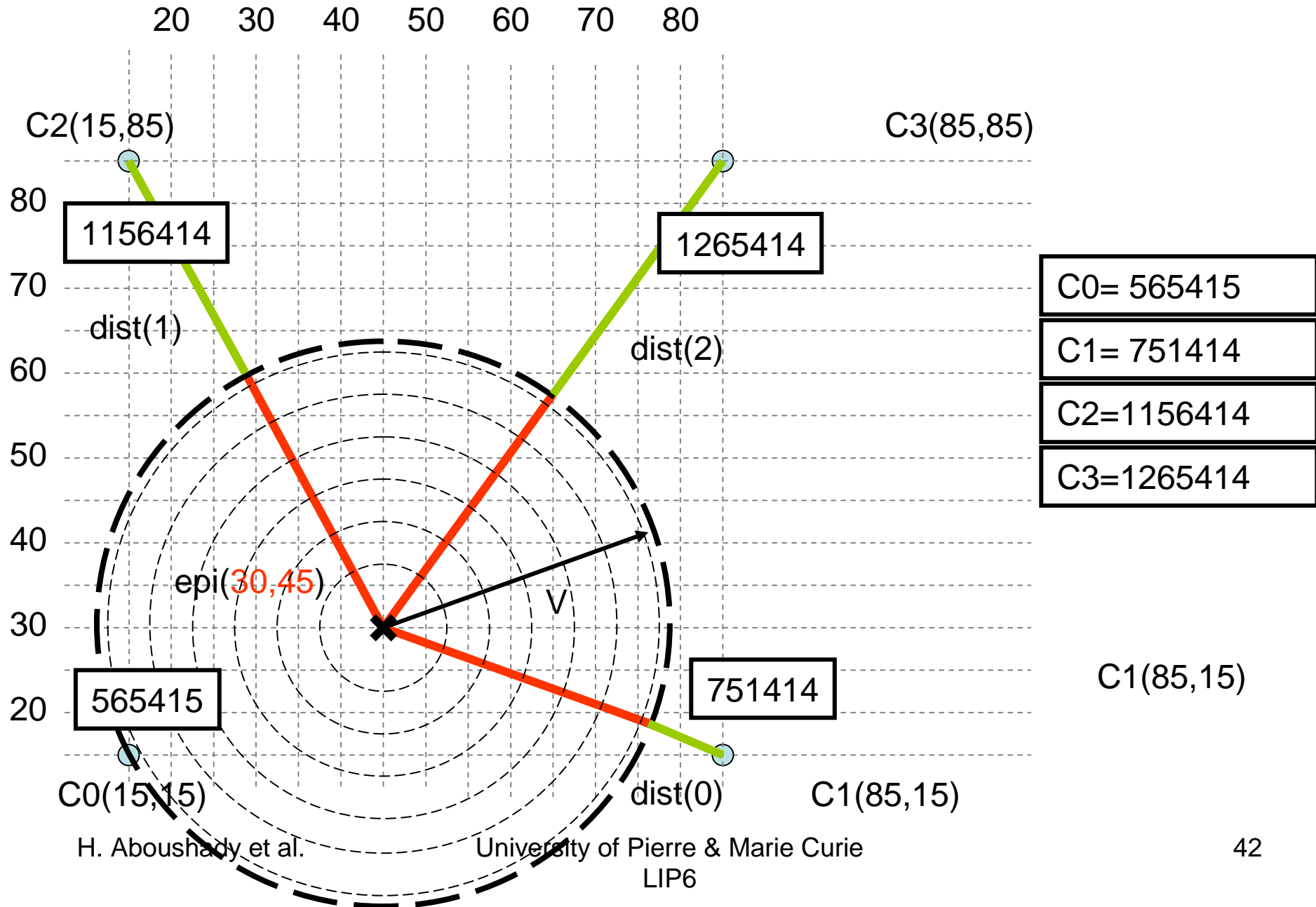

Geometry (3)

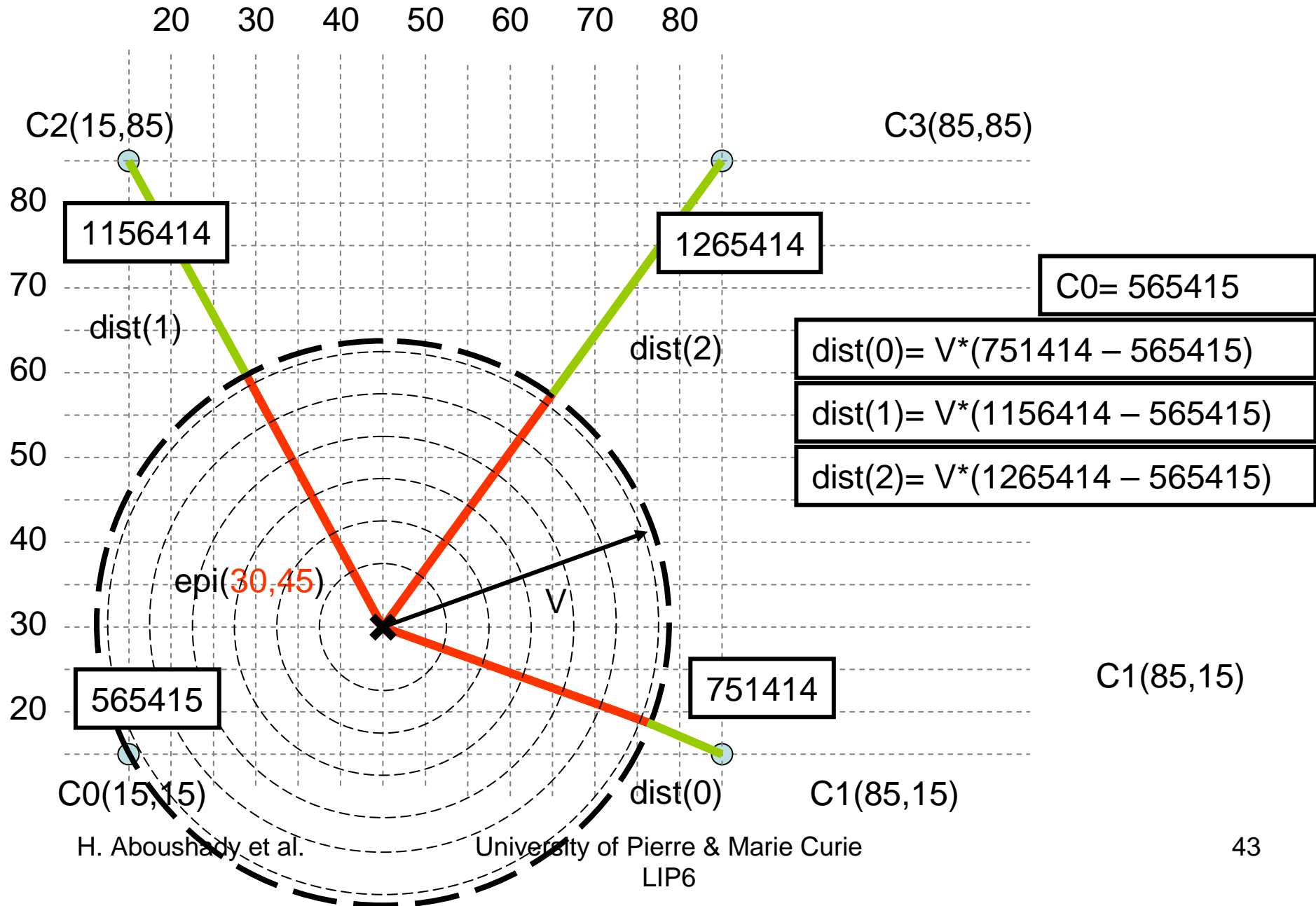

Geometry (4)

$$\sqrt{(x_{c_1} - x_e)^2 + (y_{c_1} - y_e)^2} = \sqrt{(x_{c_0} - x_e)^2 + (y_{c_0} - y_e)^2} + dist(0) \quad (1)$$

$$\sqrt{(x_{c_2} - x_e)^2 + (y_{c_2} - y_e)^2} = \sqrt{(x_{c_0} - x_e)^2 + (y_{c_0} - y_e)^2} + dist(1) \quad (2)$$

$$\sqrt{(x_{c_3} - x_e)^2 + (y_{c_3} - y_e)^2} = \sqrt{(x_{c_0} - x_e)^2 + (y_{c_0} - y_e)^2} + dist(2)$$

Use euclidian distance and Pythagore's theorem
Keep only the two former equations (1) and (2)

Geometry (5)

$$f_1(x_e, y_e) = \sqrt{(x_{c_1} - x_e)^2 + (y_{c_1} - y_e)^2} - \sqrt{(x_{c_0} - x_e)^2 + (y_{c_0} - y_e)^2} - \text{dist}(0) = 0$$
$$f_2(x_e, y_e) = \sqrt{(x_{c_2} - x_e)^2 + (y_{c_2} - y_e)^2} - \sqrt{(x_{c_0} - x_e)^2 + (y_{c_0} - y_e)^2} - \text{dist}(1) = 0$$

- Can be rewritten as a system of 2 implicit functions
- Is a system of two non-linear equations
- Can be solved by an iterative approach
 - pick up initial solution for (x_e, y_e)
 - then iterate while necessary
 - 1) **linearization of the system**
 - 2) **gaussian elimination, find roots**

Outline

- **Introduction**
- **SystemC-AMS Models**
- **Model Refinement Based on Transistor-Level Characterization**
- **MEMS in SystemC-AMS**
 - **Bandpass $\Sigma\Delta$ ADC with RF BAW resonator**
- **Application: Wireless Seismic Sensor Network**
- **Conclusion**

Conclusion

- **SystemC-AMS can be used to model complex heterogeneous systems including:**
 - **Analog and RF blocks with accurate models extracted from transistor-level characterization.**
 - **Advanced Digital blocks with embedded software managing:**
 - **RF communication standards**
 - **Solving a system of non-linear equations**
- **This environment can be very useful in optimizing the design of highly heterogeneous such as Wireless Sensors Network.**

References

WSN modeling in SystemC-AMS

[BMAS07] Michel Vasilevski, Francois Pecheux, Hassan Aboushady, Laurent de Lamarre
"Modeling Heterogeneous Systems Using SystemC-AMS Case Study: A Wireless Sensor Network Node"
International Behavioral Modeling and Simulation Conference, San Jose, CA, USA, September 2007.

[DATE08] M. Vasilevski, F. Pecheux, N. Beilleau, H. Aboushady, K. Einwich
"Modeling and Refining Heterogeneous Systems With SystemC-AMS: Application to WSN"
Design, Automation and Test in Europe, Munich, Germany, March 2008.

Automatic Model Refinement

[ISCAS09] M. Vasilevski, H. Aboushady, M.M. Louerat, "Automatic Model Refinement of GmC Integrators for High-Level Simulation of Continuous-Time Sigma-Delta Modulators"
International Symposium on Circuits and Systems, Taipei, Taiwan, May 2009.

RF LC Bandpass $\Sigma\Delta$

[RFIC09] N. Beilleau, H. Aboushady, F. Montaudon and A. Cathelin, "A 1.3V 26mW 3.2GS/s Undersampled LC Bandpass Sigma-Delta ADC for a SDR ISM-band Receiver in 130nm CMOS",
IEEE Radio Frequency Integrated Circuits Symposium, RFIC'09, Boston M.A., U.S.A, June 2009.

RF BAW Bandpass $\Sigma\Delta$

[ISCAS09] F. Javid, H. Aboushady, N. Beilleau and D. Morche, "The Design of RF Bandpass Sigma-Delta Modulators with Bulk Acoustic Wave Resonators", IEEE International Symposium on Circuits & Systems, ISCAS'09, Taipei, Taiwan, May 2009.

Wireless seismic sensor network

[HETER09] F. Pecheux, H. Aboushady et J. Denoulet, « Modelisation de systemes heterogenes", Cours Master SESI, Systeme Electronique Systeme Informatique, Universite Pierre et Marie Curie, Paris VI.